

Speaker Stand

VF119M (medium oak) • VF119E (mahogany)

Vertiflex
Products™

Assembly Instructions

www.advantus.com

904.482.0091



General Instructions

It is recommended that two people be used to assemble this product.

Hex wrench provided for most assembly steps. See Hardware List

Tools required - #2 Phillips screwdriver

CAUTION:
POWER TOOLS ARE NOT RECOMMENDED

LAY PARTS ON FLAT, NON-SCRATCH SURFACE

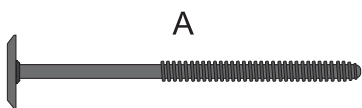

A
70mm HEX BOLT
#119-0-A
(1)

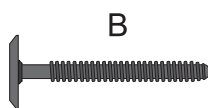

B
40mm HEX BOLT
#119-0-B
(1)



C
1/2" SCREW
#119-0-C
(6)

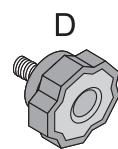

D
ADJUSTMENT KNOB
#119-0-D
(2)

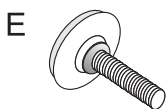

E
LEVELER GLIDES
#119-0-E
(4)



F
HEX NUT
#119-0-F
(1)



G
METAL WASHER
#119-0-G
(1)



H
PLASTIC SPACER
#119-0-H
(1)

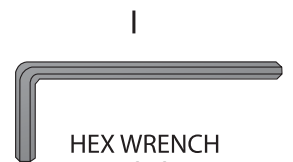

I
HEX WRENCH
#243
(1)

1 Check All Parts and Hardware

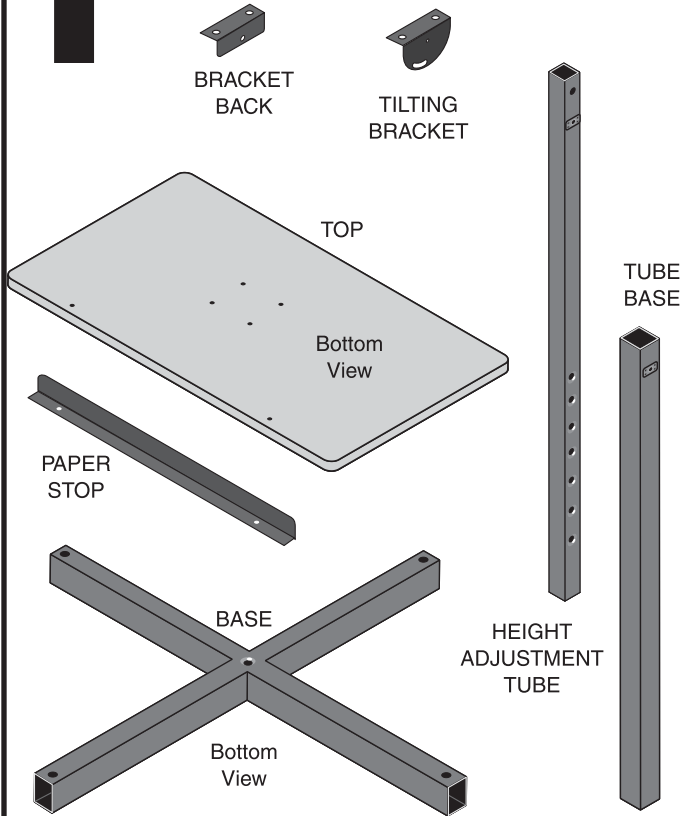

2 Prepare Top

Attach TILTING BRACKET, BRACKET BACK and PAPER STOP to TOP with 1/2" SCREWS (C) as shown. FIG. 2

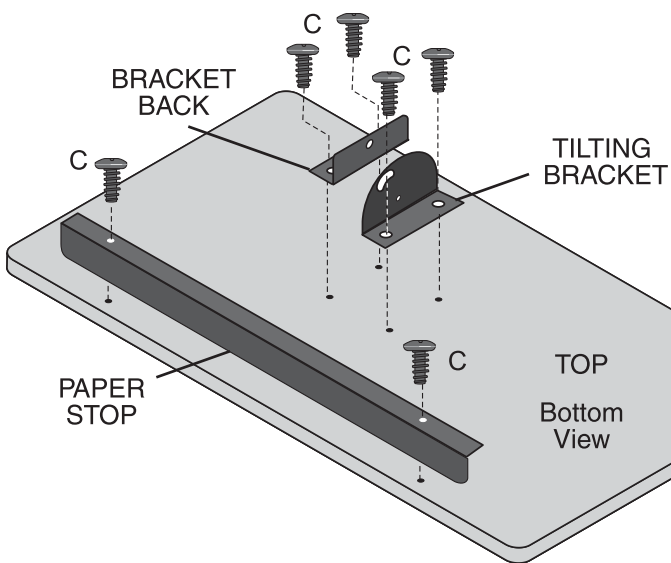

FIG. 2

3 Attach Tubes to Base and Top - Join

Attach HEIGHT ADJUSTMENT TUBE to TOP. METAL WASHER (G) and PLASTIC SPACER (H) install between TUBE and BRACKETS. Tighten with HEX WRENCH (I).

Install (4) LEVELER GLIDES (E) to BASE as shown. Attach BASE TUBE to BASE. Tighten with HEX WRENCH (I).

Slide BASE TUBE onto HEIGHT ADJUSTMENT TUBE and install ADJUSTMENT KNOB (D). Turn assembly over.

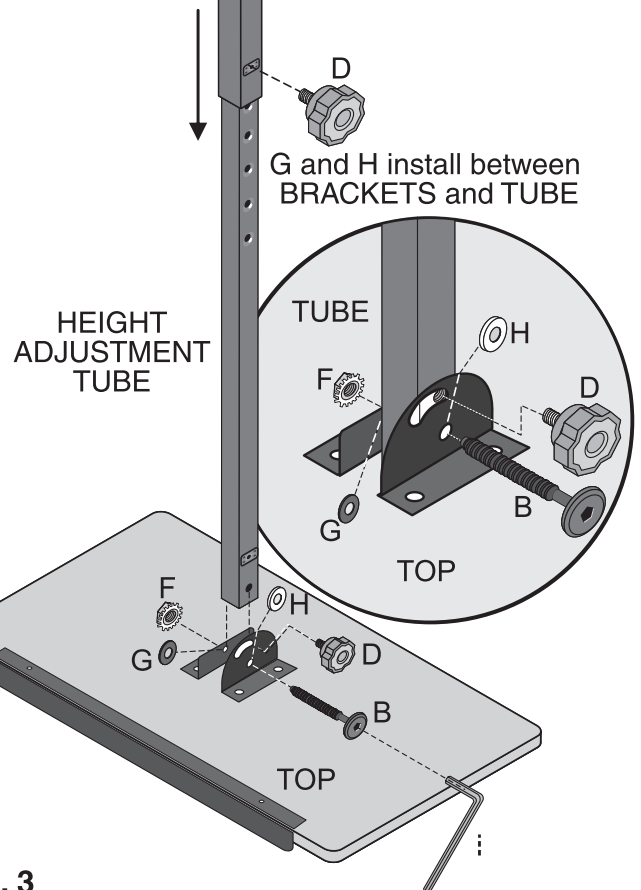
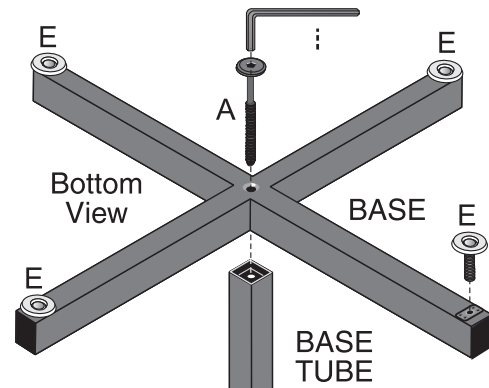

FIG. 3