

**NOT
For Customer
Service Only
ORIGINAL**

m&m
INDUSTRIES INC.

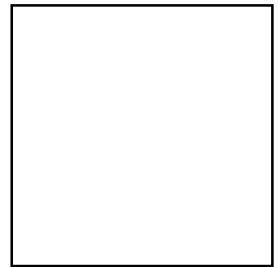

**REFER TO THIS
INSPECTION NUMBER
WHEN CALLING FOR
SERVICE**

**ASSEMBLY INSTRUCTIONS FOR:
21402**

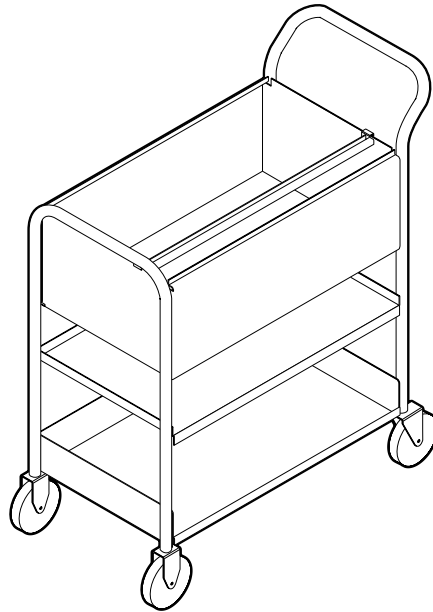

Mail Cart

ASSEMBLY PREVIEW

The parts provided are for assembly of a Mail Cart.

If you're like us, you'll try to assemble this unit without reading the directions. **PLEASE DON'T.** A few minutes now may save a lot of disassembly and reassembly later!

Unpack the carton the unit came in. Be sure to remove everything.

Before starting, check the parts against the parts list. Separate, identify and count all hardware parts. Assembly will be much easier if this is done first.

A Phillips screwdriver is needed for assembly.

To assure the prompt and accurate handling of a claim in the event of damage, this unit must be packed in its original carton in the same manner as which it was shipped. Failure to do this may result in a claim denial.

**SHOULD YOU HAVE ANY QUESTIONS CONCERNING THE ASSEMBLY OF THIS UNIT,
(OR ARE MISSING ANY PARTS) PLEASE CALL US AT:**

1-800-323-4613

Hardware & Parts List

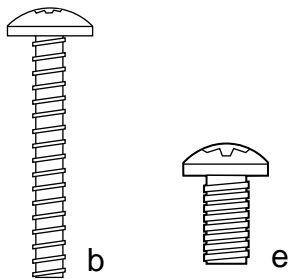
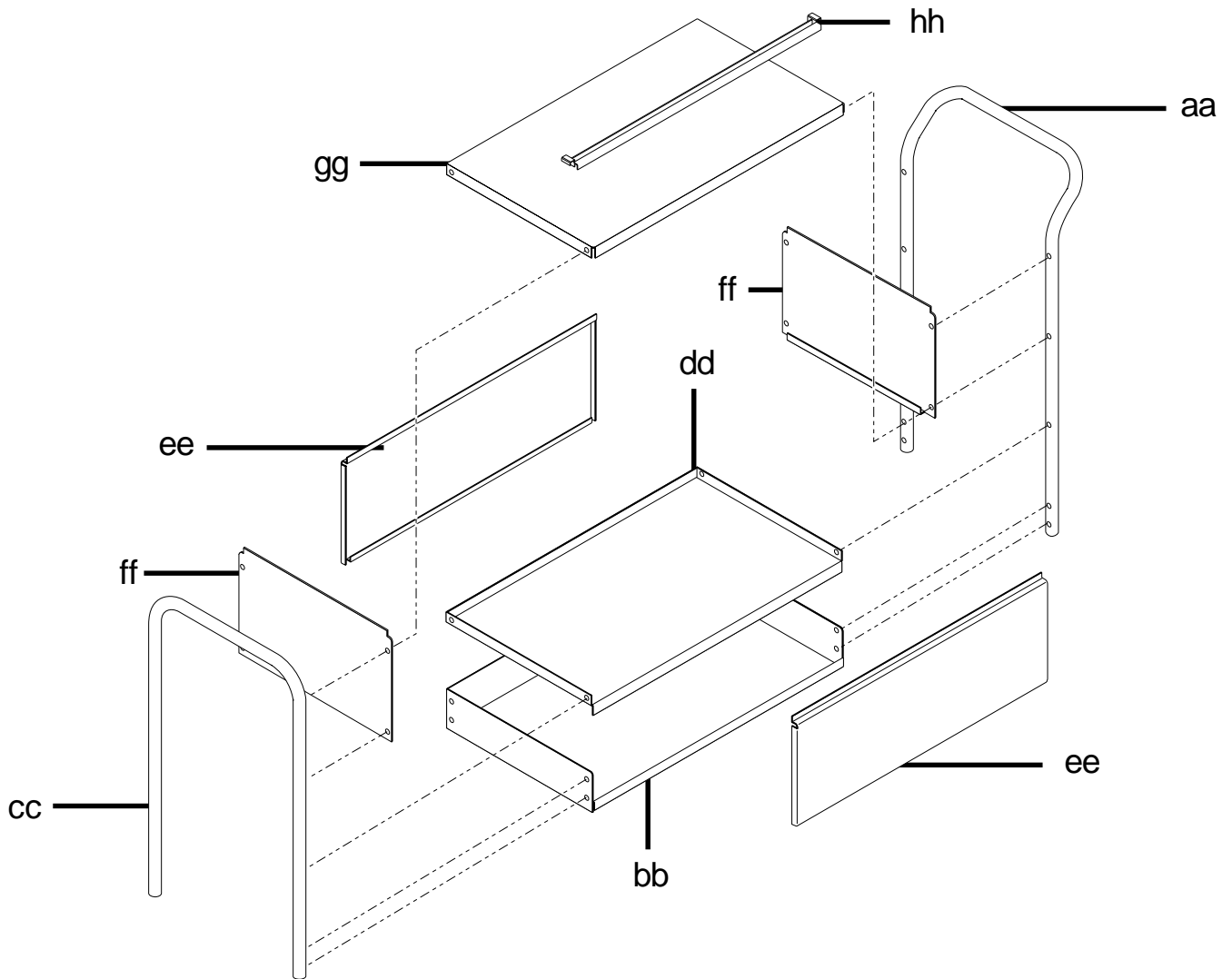

These items are actual size

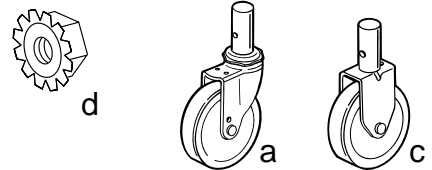

These items are not actual size

ITEM	DESCRIPTION	QTY	ITEM	DESCRIPTION	QTY
aa	LONG LEG TUBE	1	hh	HANGER BAR	1
bb	LOWER SHELF	1	a	SWIVEL CASTER	2
cc	SHORT LEG TUBE	1	b	PAN HEAD SCREWS 1/4-20	4
dd	MIDDLE SHELF	1	c	FIXED CASTER	2
ee	SIDE PANEL	2	d	1/4 -20 KEPS NUT	4
ff	END PANEL	2	e	PAN HEAD SCREW #14 x 1/2	16
gg	UPPER SHELF	1			

1

It is a good idea to assemble the Mail Cart on a carpet to avoid scratching it. If this is not possible, you can use the cardboard box the unit came in as a work surface (**Be sure to remove all staples!**).

First, insert Swivel Casters (a) into Long Leg Tube (aa). Line up screw holes in the caster with screw holes in tube. Position Lower Shelf (bb) lining up holes. Insert one Pan Head Screw 1/4-20 (b) through each hole in Long Leg Tube, Casters and Shelf. Secure using a 1/4 20 Keps Nut (d) on each screw.

Repeat with Short Leg Tube (cc) and Fixed Casters (c). Insert two Pan Head Screws 1/4-20 (b) through holes in Short Leg Tube, Casters and Shelf. Secure using a 1/4-20 Keps Nut (d). Also insert four Pan Head Screws #14 x 1/2 (e) into remaining holes on Lower Shelf to secure Leg Tubes.

NOTE: Do not tighten any nuts or bolts until the entire Mail Cart is assembled.

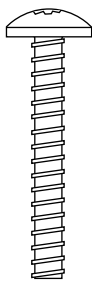
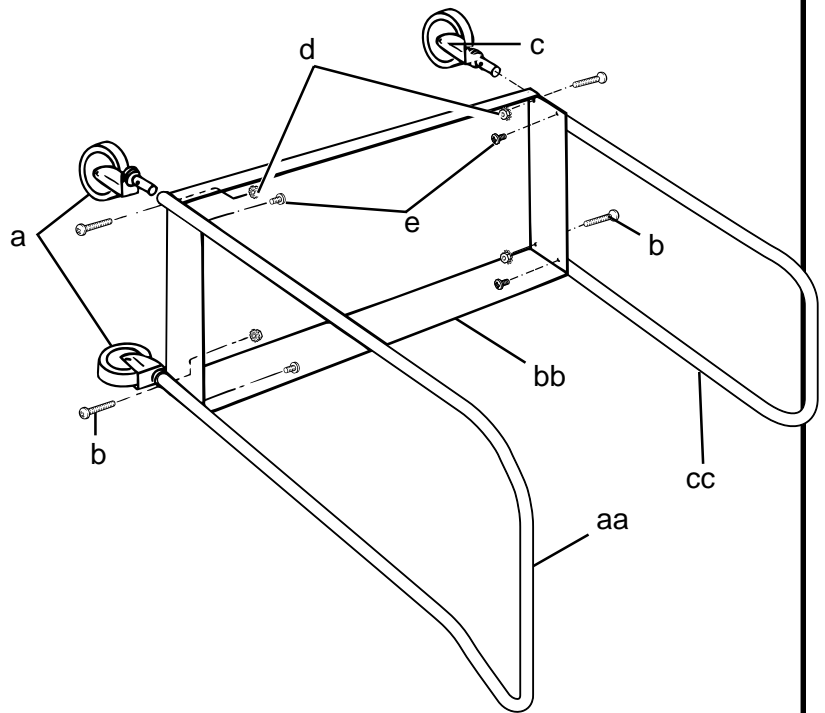

b (4)



d (4)

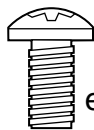

e (4)

2

Then, attach Middle Shelf (dd) to Leg Tubes using two Pan Head Screws #14 x 1/2 (e) for each Leg Tube.

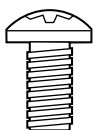
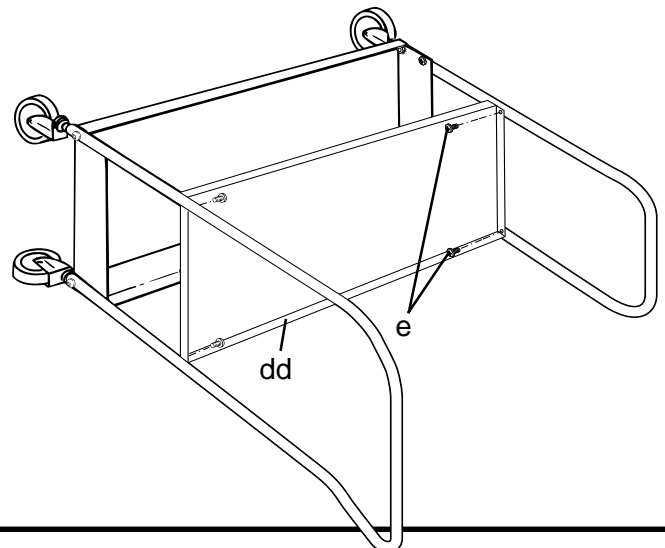

e (4)

3

Turn the Mail Cart up on its end so that the Swivel Casters are towards the floor.

Put the Side Panel (ee) in first and line up the holes with the ones in the Leg Tube, then put the End Panel (ff) in place on top lining up both sets of holes. Now attach the panels using two Pan Head Screws #14 x 1/2 (e).

Repeat step for other Side and End Panel.

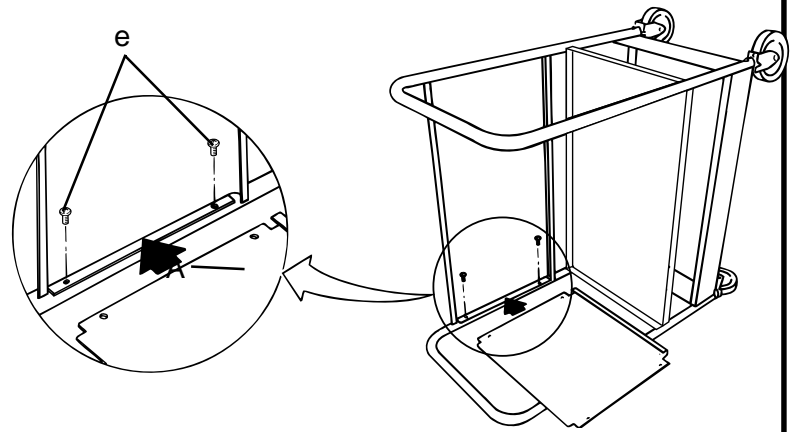
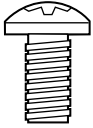

4

After loosely securing the Side and End Panels it's time to attach the Upper Shelf (gg). Turn the cart right side up and place the Upper Shelf in position as shown.

NOTE: At this point you can tighten up all of the fasteners.

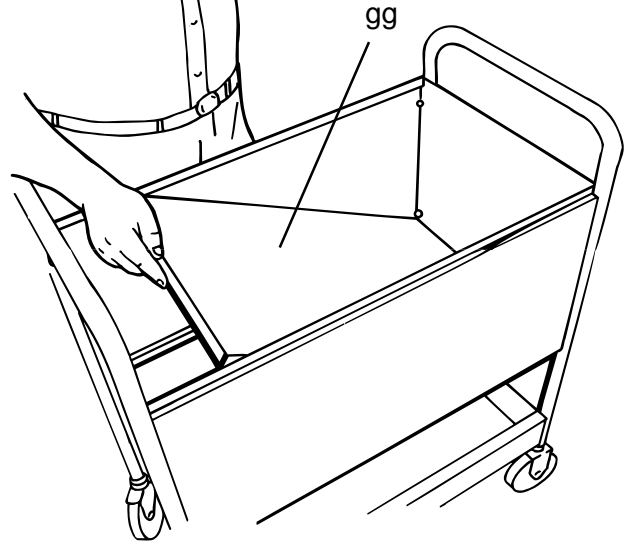

5

The Mail Cart can be used with standard or legal size folders. The Hanger Bar (hh) can be positioned to accommodate either one. With the Hanger Bar removed entirely data binders may be hung in the Mail Cart.

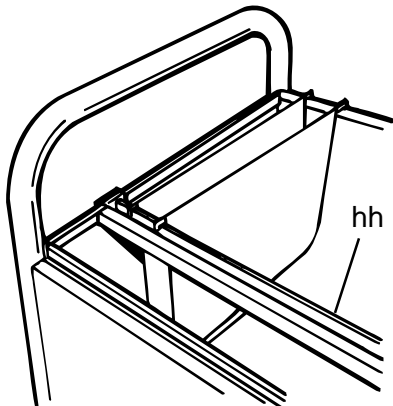

Hanger Bar position for standard size folders

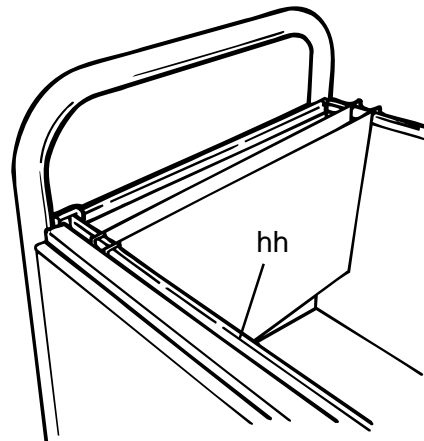

Hanger Bar position for legal size folders