

Vertiflex™ Products

MOBILE PRINTER CART

MODEL 345

GENERAL INSTRUCTIONS

To facilitate the assembly of this product, special fittings have been pre-mounted on some panels. After installation of **SHOULDER SCREWS** onto the edges of some panels, all that is needed to fasten the panels is to match the male and female fittings, tap the panels gently to insure a good fit and **turn the phillips head on the female fitting clockwise**, using a phillips screwdriver.

If the panels need to be taken apart, simply reverse the procedure. **Care must be taken, however, so as not to damage the fittings.**

IMPORTANT

SHOULDER SCREWS (male fittings) mounted on the edges of the panels are **NOT CENTERED** (See figure below). The portion which has the shortest distance to the edge of the panel **MUST** be adjacent to the phillips screw head on the female fitting. To aid in assembly, parts have been stamped with an **ARROW** on the **EDGE** to indicate direction of this offset.

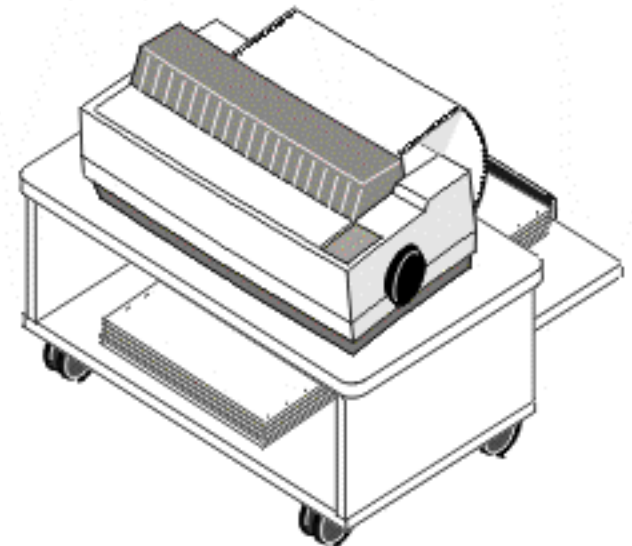
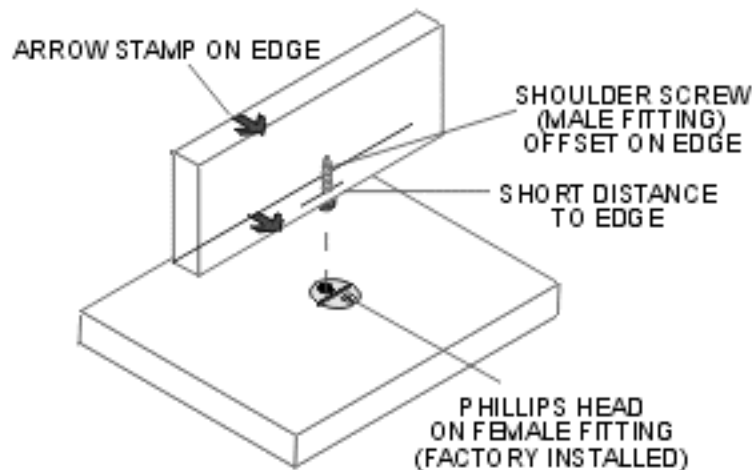

TOOLS REQUIRED

#2 PHILLIPS SCREWDRIVER
HAMMER

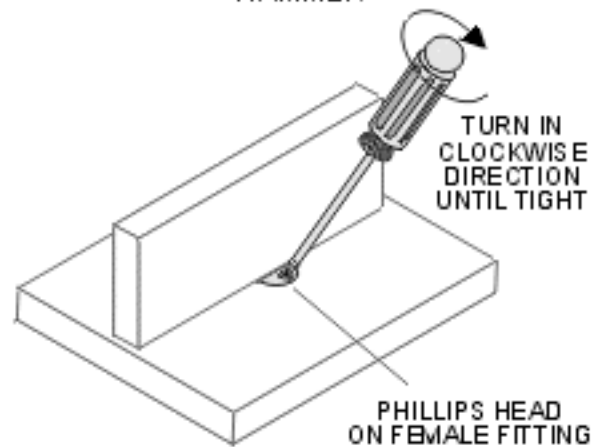

HARDWARE LIST

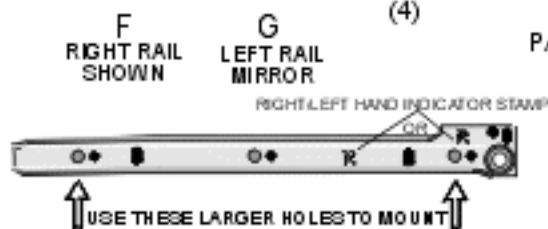
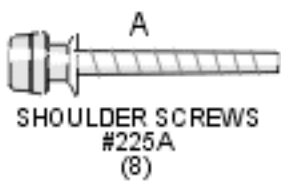

14" CABINET RAIL
#387
1 RIGHT / 1 LEFT

14" DRAWER RAILS
#387D
1 RIGHT / 1 LEFT



1. IDENTIFY ALL PARTS.

If any parts are missing OR you have questions about assembly, please call CUSTOMER SERVICE 1-800-966-5511 Monday - Friday 8am. TO 5pm. (Pacific)

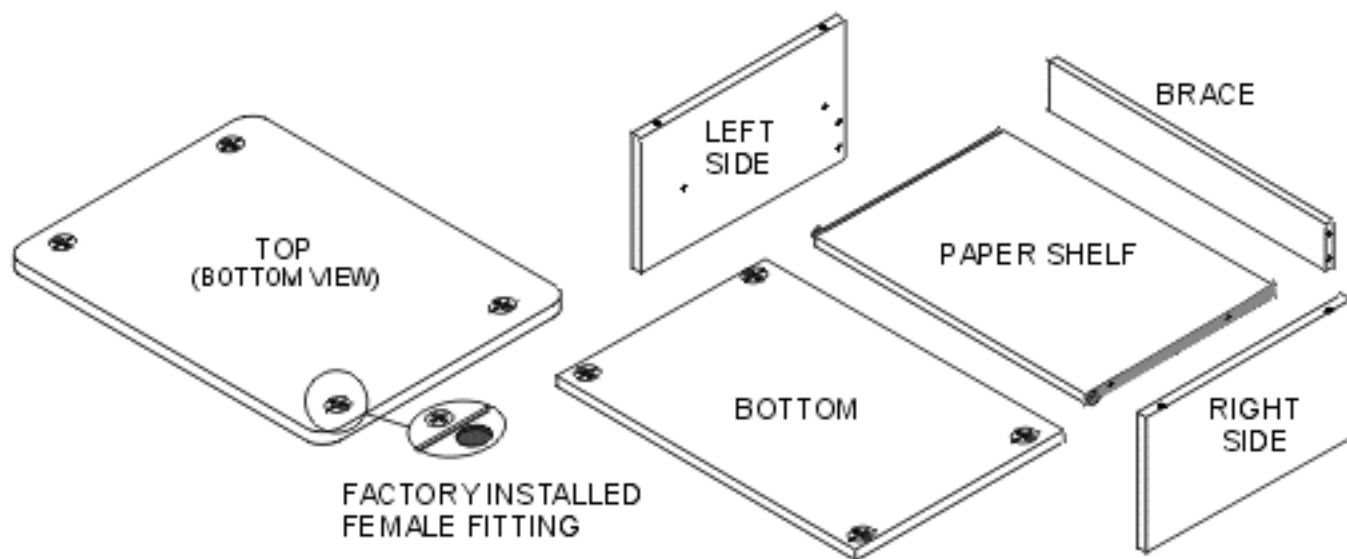

IDENTIFY PARTS FROM PARTS LIST BELOW:

NO.	WOOD PART LIST	WOOD PART SIZES			WOOD PART NUMBERS
		THICKNESS	WIDTH	LENGTH	
1	RIGHT SIDE	5/8"	X 11-5/8"	X 15-1/8"	345-RSIDE + COLOR
1	LEFT SIDE	5/8"	X 11-5/8"	X 15-1/8"	345-LSIDE
1	TOP	5/8"	X 15-3/4"	X 23-5/8"	340-TOP
1	BRACE	5/8"	X 4"	X 20"	340-BRACE
1	PAPER SHELF	5/8"	X 11"	X 19"	340-PAPRSHLF
1	BOTTOM	5/8"	X 11-1/8"	X 21-1/4"	340-BOTTOM

2. PREPARE HARDWARE ON SIDES

Lay RIGHT and LEFT SIDES on a flat, non-scratch surface, with holes facing up. FIG. 1 Align and attach LEFT RAIL (G) to RIGHT SIDE using (2) 5mm EUROSCREWS (B). Align and attach RIGHT RAIL (F) to LEFT SIDE using (2) 5mm EUROSCREWS (B). Install (4) SHOULDER SCREWS (A) into edges of each SIDE.

Insert (2) 5mm WOOD DOWEL PINS (D) into 2 holes near corner of panel by pressing into place and gently tapping with handle of screwdriver, or other striking tool.

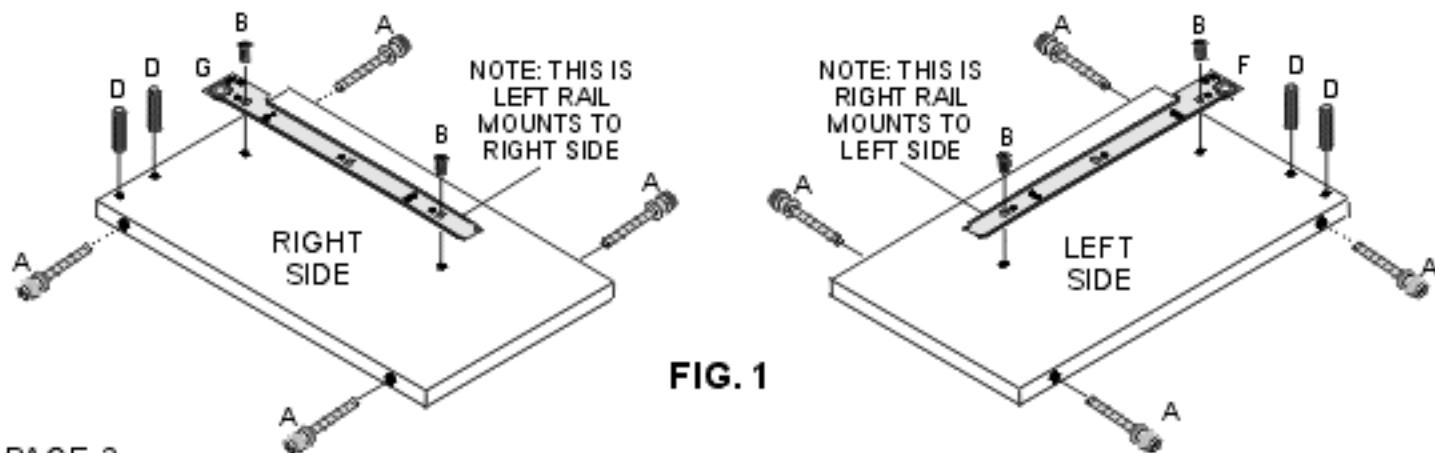
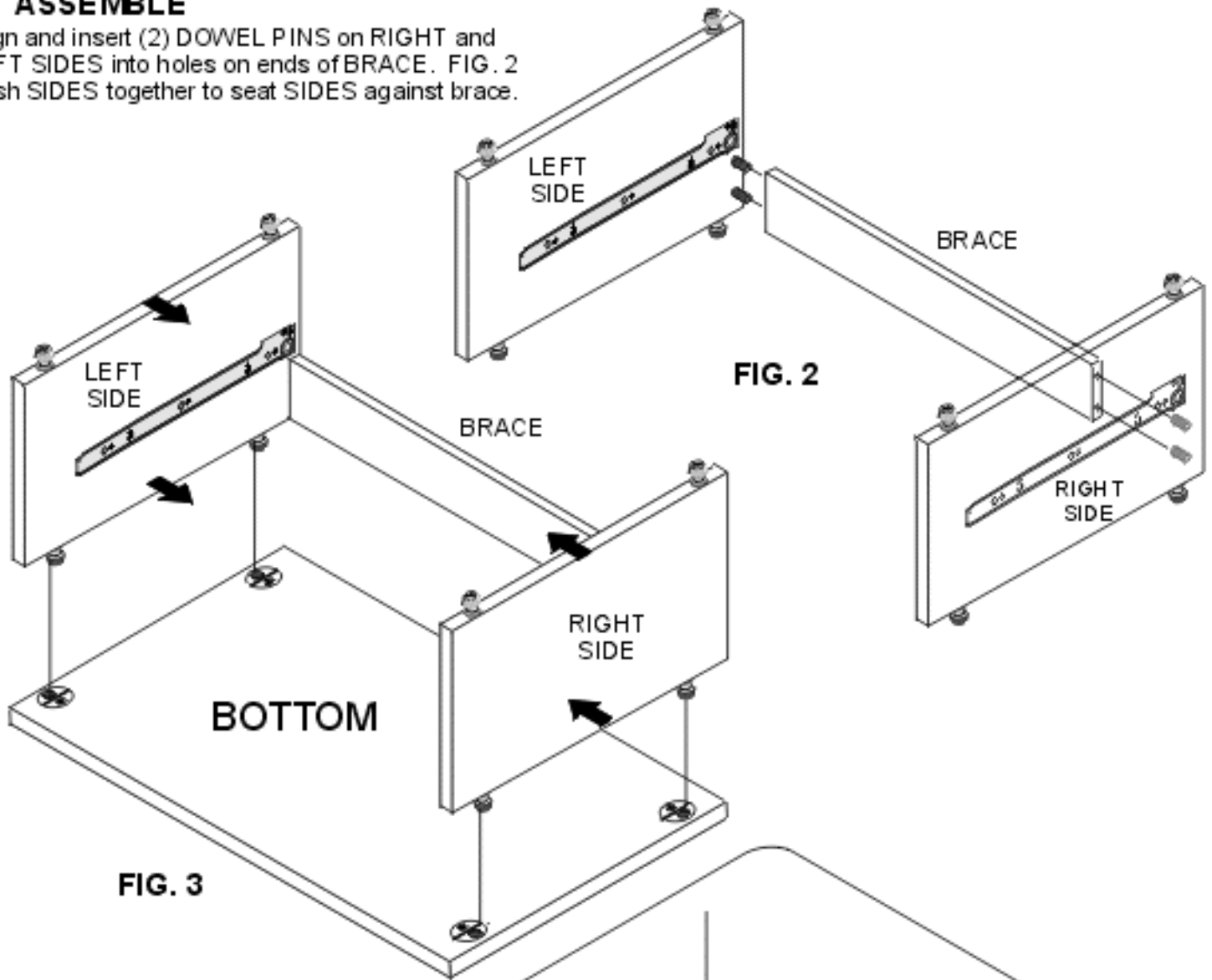

FIG. 1

3. ASSEMBLE

Align and insert (2) DOWEL PINS on RIGHT and LEFT SIDES into holes on ends of BRACE. FIG. 2 Push SIDES together to seat SIDES against brace.



4. ASSEMBLE

Lay BOTTOM on a flat, non-scratch surface, assembly fittings facing up. While holding BRACE and SIDES together align and attach LEFT and RIGHT SIDES to BOTTOM. Confirm direction of ARROWS to inside of unit. FIG. 3 Tighten fittings into holes on ends of BRACE. FIG. 2 Push SIDES together to seat SIDES against brace.

5. ASSEMBLE

Align and attach TOP to RIGHT and LEFT SIDES. FIG. 4. Tighten fittings.

TURN UNIT OVER ONTO TOP ON A FLAT, NON-SCRATCH SURFACE.

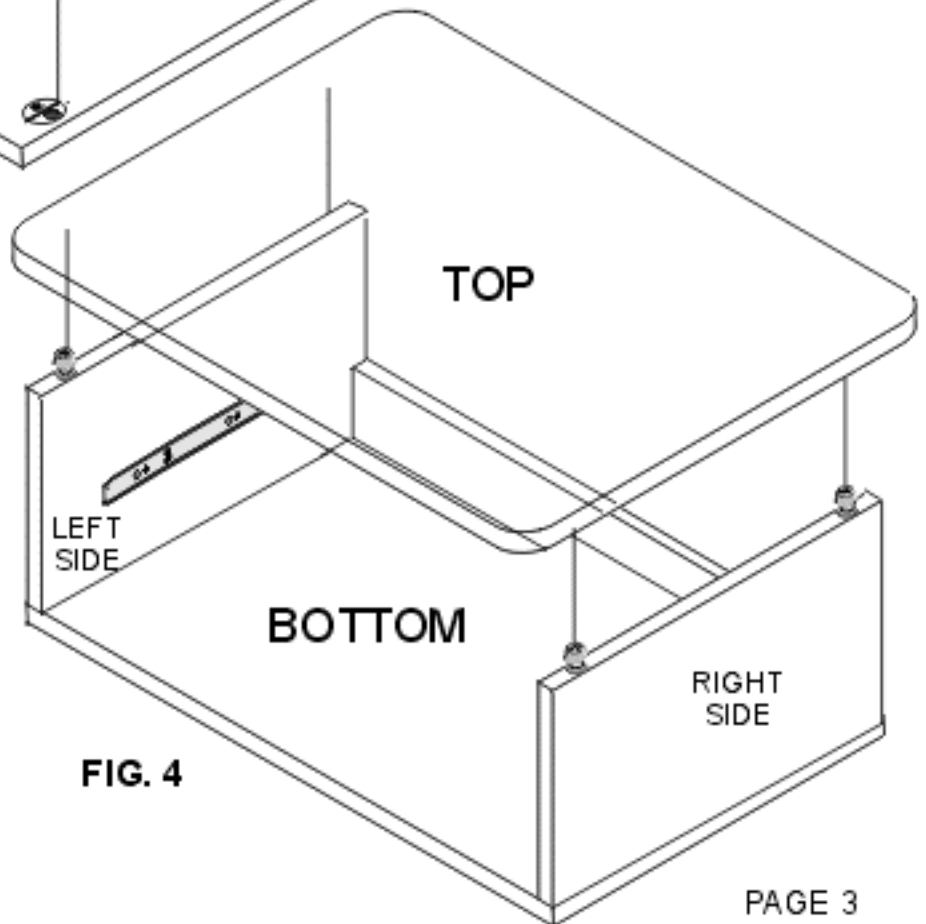

6. INSTALL CASTERS

Align and insert (4) CASTERS (C) into pre-installed fittings on underside of BOTTOM.

FIG. 5

Some force may be needed to "dick" casters into inserts.

TURN UNIT OVER ONTO CASTERS.

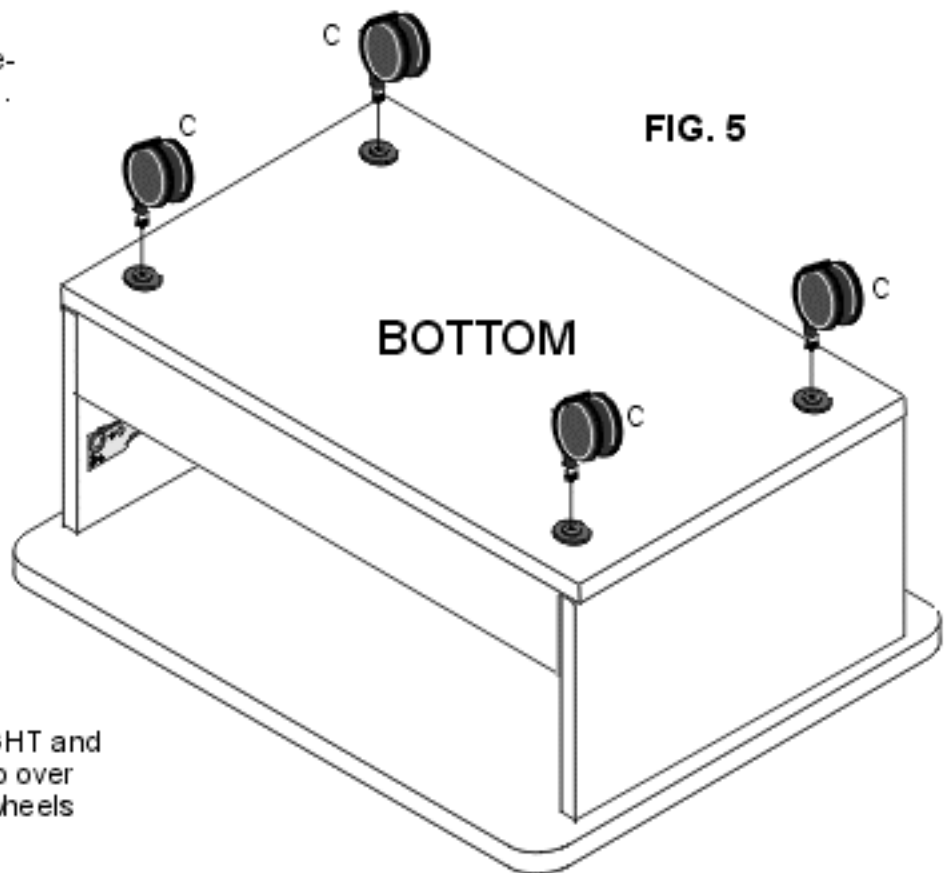

7. INSTALL SHELF

Install PAPER SHELF onto RAILS on RIGHT and LEFT SIDES. FIG. 6. Wheels on shelf go over and behind wheels on cabinet. Engage wheels into track and push in.

Align and attach (1) PAPER STOP (H) to edge of PAPER SHELF as shown using (3) #6 x 5/8" PAN HEAD SCREWS (E). Textured side faces out.

FIG. 6

