

# Vertiflex™ Products

## NOTES ON ASSEMBLY

- Use caution during assembly, unbanded edges can be sharp and may chip if mishandled.
- Remove staples, (if any) from carton and use carton to set parts on during assembly.
- Page two of this instruction sheet contains an illustrated parts list and phone number to call in case of missing hardware. The parts list also contains drawings of the screws and other hardware as an easy identification guide.

## TOOLS REQUIRED

- #2 PHILIPS SCREWDRIVER – CAM BOLT
- #6 FLAT SCREWDRIVER – CAM

POWER TOOLS ARE NOT RECOMMENDED

## TABLE TOP LECTERN

### ASSEMBLY INSTRUCTIONS

50058C OAK

50059C WALNUT

50266C MAHOGANY

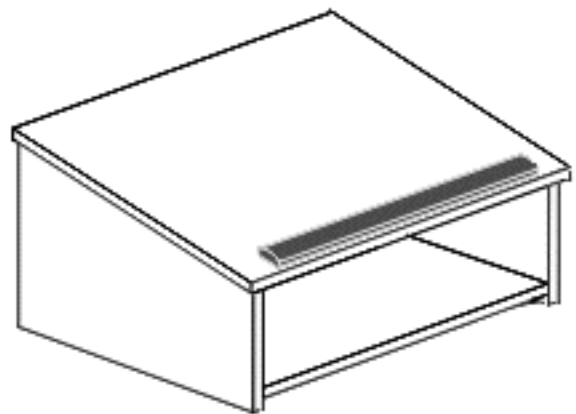

## CAM LOCK ASSEMBLY

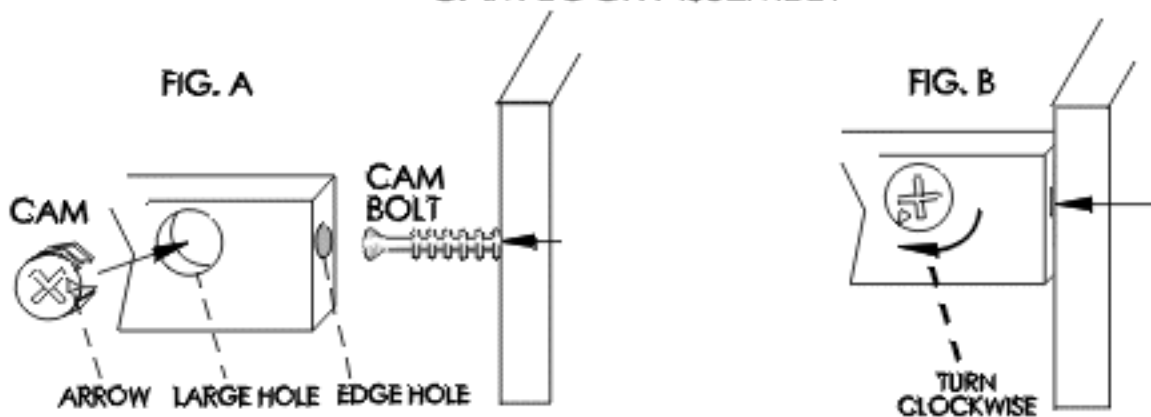

- Insert CAM, with arrow pointing to edge hole, into large hole in face of panel as shown in FIG. A
- Fully insert CAM BOLT, installed on adjoining panel, into edge hole as shown in FIG. A and FIG. B
- Turn CAM clockwise 1/3 rotation to lock panels together. FIG. B. For additional security, CAM may be turned another 1/4 turn.

PAGE 1

50058-59-266

# 1. IDENTIFY ALL PARTS.

If any parts are missing OR you have questions about assembly, please call CUSTOMER SERVICE 1-800-966-5511 Monday -Friday 8am . TO 4:30pm . (Central)

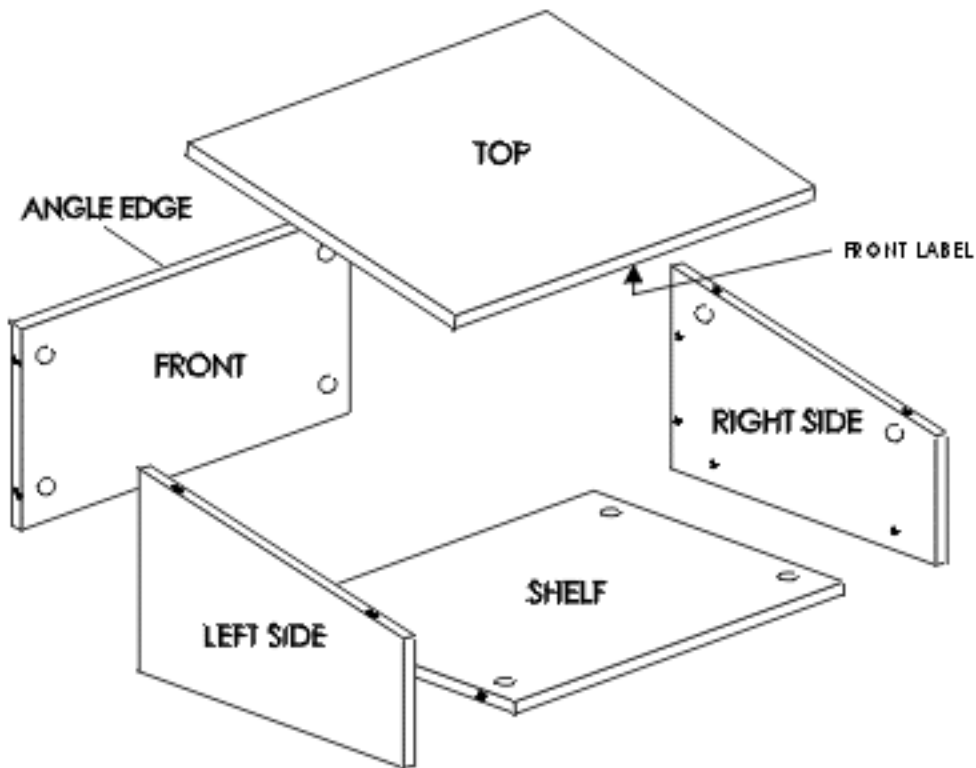

IDENTIFY PARTS FROM SIZE LISTING BELOW

NO.	WOOD PART LIST	WOOD PART SIZES		WOOD PART NUMBERS BY COLOR		
		WIDTH	LENGTH	OAK	WALNUT	MAHOGANY
1	FRONT	21-1/4"	X 12-13/16"	58COAK-FRONT	59CWAL-FRONT	266CMAH-FRNT
1	LEFT SIDE	18-1/2"	X 13"	58COAK-LSIDE	59CWAL-LSIDE	266CMAH-LSID
1	RIGHT SIDE	18-1/2"	X 13"	58COAK-RSIDE	59CWAL-RSIDE	266CMAH-RSID
1	SHELF	16-3/4"	X 21-1/4"	58COAK-SHELF	59CWAL-SHELF	266CMAH-SHLF
1	TOP	19-13/16"	X 23-3/4"	58COAK-TO P	59CWAL-TOP	266CMAH-TO P

A



CONNECTING CAMBOLT  
#212  
(12)

B



19mm CAM  
#213  
(12)

PAPER STOP  
#793  
(1)



HOTTO SCALE

PAGE 2

50058-59-266

## 2 BEGIN ASSEMBLY BY INSTALLING HARDWARE AS SHOWN BELOW.

- The LETTERS next to the hardware shown refer to the same letters next to the hardware in the Parts List.
- When installing CAM BOLTS, be sure to tighten until shoulder rests on panel surface, as shown in FIG. C. Cams are inserted with CAM ARROWS pointing to the corresponding edge with the edge hole.

FIG. C

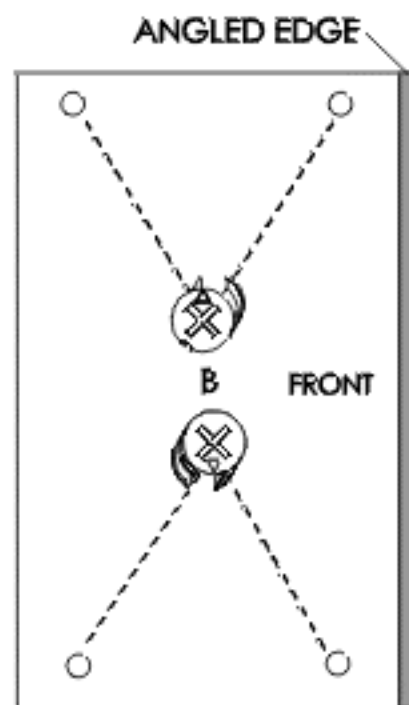
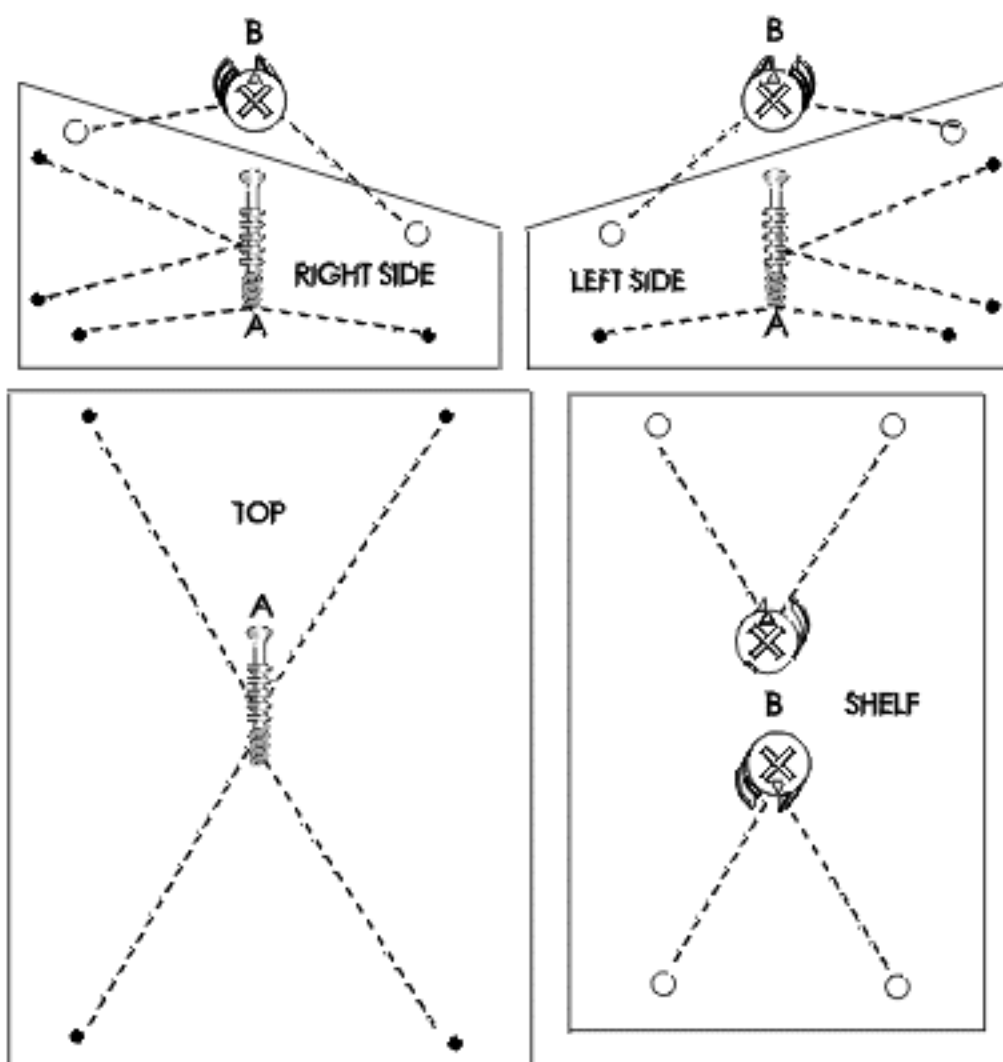

### 3 ASSEMBLY OF CABINET

- NOTE: THE ARROW ON THE CAM MUST POINT TO THE CAM BOLT AS PANELS ARE ALIGNED FOR FASTENING. DO NOT PUT STRESS ON VERTICAL PANELS DURING ASSEMBLY. KEEP PANELS SUPPORTED DURING FASTENING. WHEN POSSIBLE, USE 2 PEOPLE FOR ASSEMBLY.

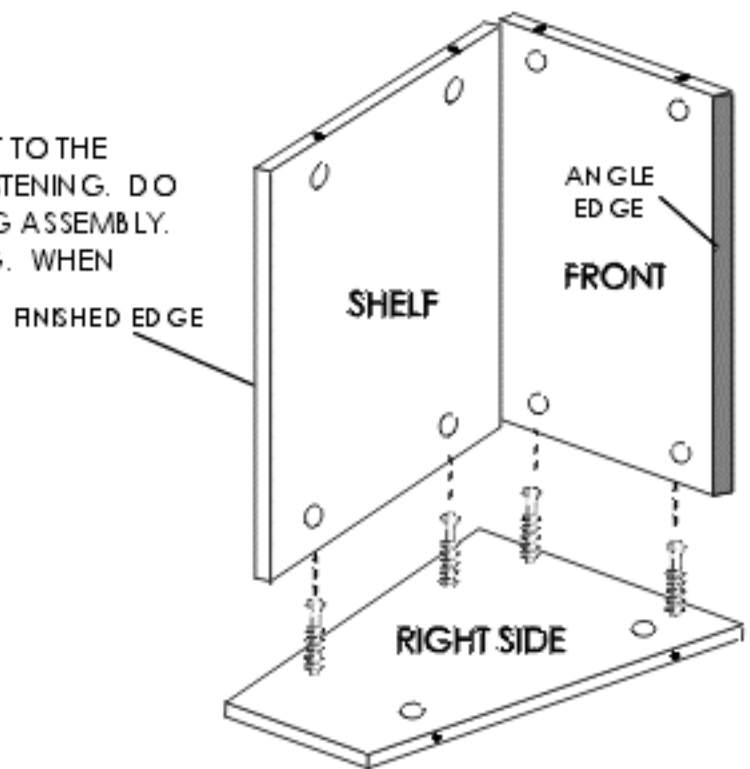
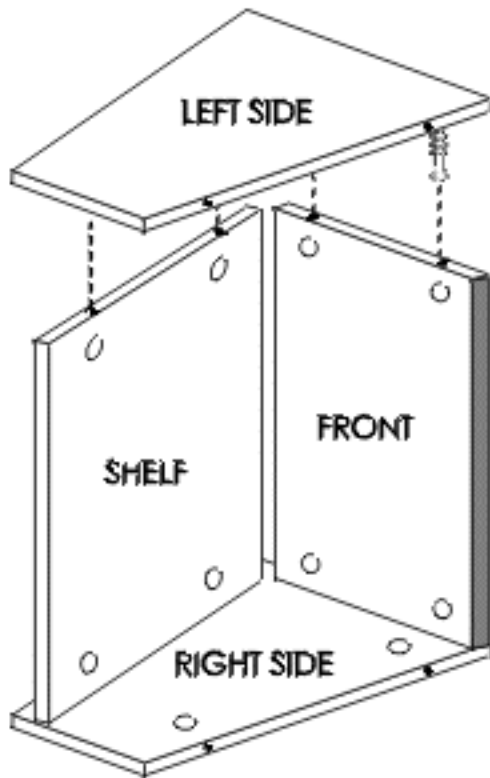

- Lay RIGHT SIDE on a flat surface, protecting surface from scratches. NOTE: All CAMS face inside at this step. Align and attach (1) SHELF with finished edge facing out. Tighten CAMS. Attach FRONT, with ANGLED EDGE facing out as shown above. Tighten CAMS.

- Align and attach LEFT SIDE to SHELF and FRONT as shown above. Tighten CAMS.
- Attach TOP to LEFT and RIGHT SIDES as shown to the right. Tighten CAMS. NOTE: FRONT LABEL
- Remove paper liner from adhesive on back of PAPER STOP. Affix centered to front edge of TOP as shown.
- Place TABLE TOP LECTERN on table surface for use. OR install on top of AUDIOVISUAL CART – LECTERN BASE MODEL #500 60 /500 61 /502 67 if that product has been purchased.

