

Vertiflex™ Products

NOTES ON ASSEMBLY

- Use caution during assembly, unbanded edges can be sharp and may chip if mishandled.
- Remove staples, (if any) from carton and use carton to set parts on during assembly.
- Page two of this instruction sheet contains an illustrated parts list and phone number to call in case of missing hardware. The parts list also contains drawings of the screws and other hardware as an easy identification guide.

TOOLS REQUIRED

- #2 PHILLIPS SCREWD RIVER – CAM BOLT
- #6 FLAT SCREWD RIVER – CAM
- HAMMER

POWER TOOLS ARE NOT RECOMMENDED

PRESIDENTIAL LECTERN

WITH SLIDING SHELF

ASSEMBLY INSTRUCTIONS

50090C MAHOGANY

50243C OAK

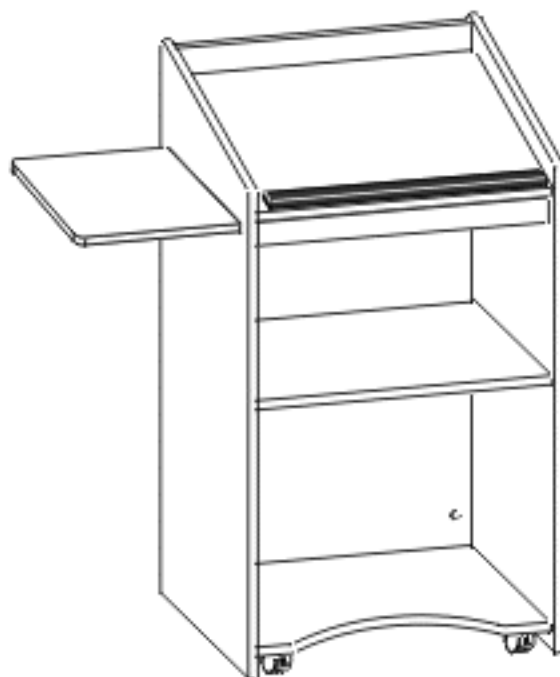

CAM LOCK ASSEMBLY

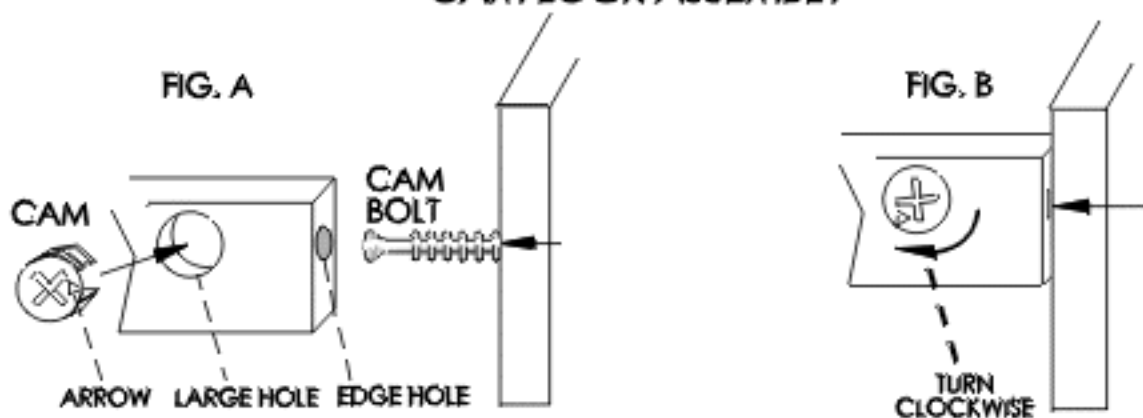

- Insert CAM, with arrow pointing to edge hole, into large hole in face of panel as shown in FIG. A
- Fully insert CAM BOLT, installed on adjoining panel, into edge hole as shown in FIG. A and FIG. B
- Turn CAM clockwise 1/3 rotation to lock panels together. FIG. B. For additional security, CAM may be turned another 1/4 turn.

1. IDENTIFY ALL PARTS.

If any parts are missing OR you have questions about assembly, please call
 CUSTOMER SERVICE 1-800-966-5511 Monday -Friday 8am. TO 4:30pm. (Central)

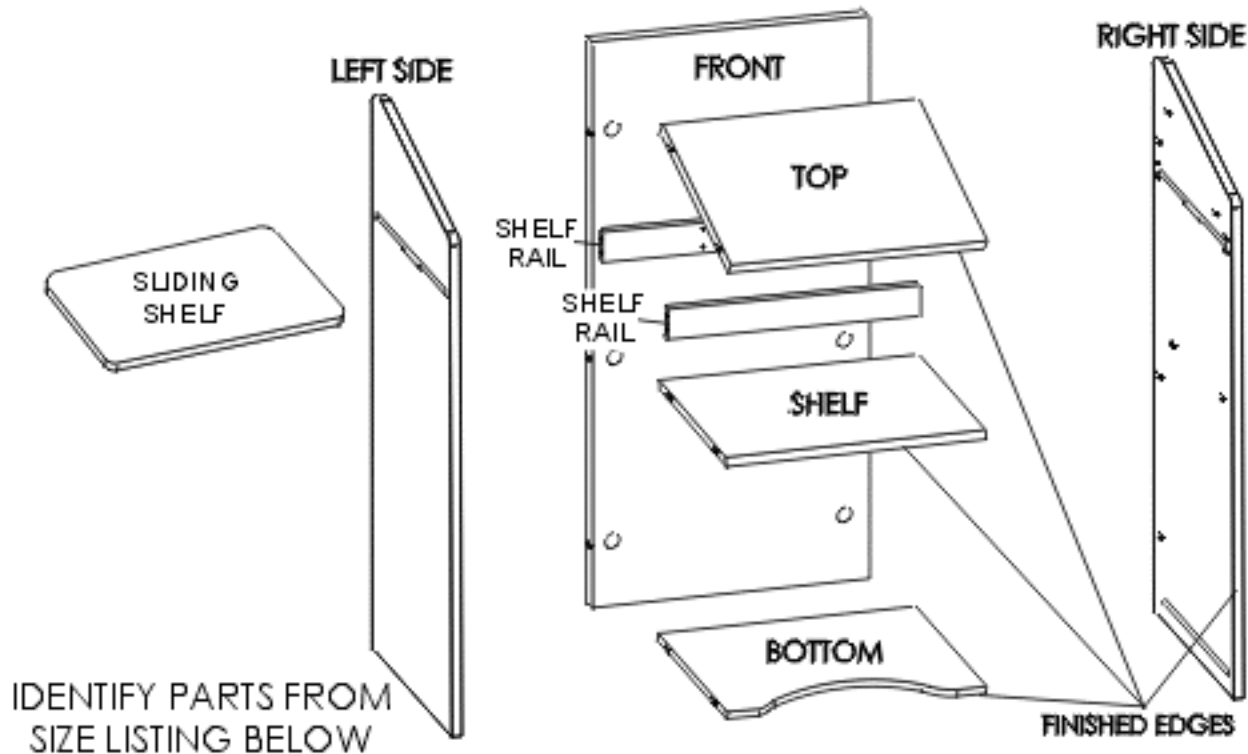

IDENTIFY PARTS FROM
 SIZE LISTING BELOW

NO.	WOOD PART LIST	WOOD PART SIZES		WOOD PART NUMBERS BY COLOR	
		WIDTH	LENGTH	OAK	MAHOGANY
1	BOTTOM	17-25/32'	X24-1/2'	243CROK-BOTT	90CRMH-BO TTM
1	FRONT	23-5/8'	X44-3/4'	243CROK-FRNT	90CRMH-FRONT
1	LEFT SIDE	19-7/8'	X45-1/4'	243CROK-LSID	90CRMH-LSIDE
1	RIGHT SIDE	19-7/8'	X45-1/4'	243CROK-RSID	90CRMH-RSIDE
1	SHELF	17-1/16	X23-5/8'	243CROK-SHLF	90CRMH-SHELF
1	TOP	18-3/4'	X23-5/8'	243CROK-TOP	90CRMH-TOP
2	SHELF RAIL	2-1/2'	X23-5/8'	243CROK-SHRL	90CRMH-SHFRL
1	SLIDING SHELF	15-3/8'	X27-1/4'	243CROK-SLSF	90CRMH-SLSHF

A

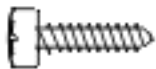

#8 X 5/8" PHILLIPS
 PAN HEAD SCREW
 PART # 178
 (10)

B



#10 X 3/4" PPH SCREW
 PART # 805
 (18)

C



PLATE CASTER LOCKING
 PART # 857
 (2)

D



PLATE CASTER NON-LOCKING
 PART # 858
 (2)

E



L BRACKET
 PART # 208
 (5)

F



19mm CAM
 PART # 213
 (14)

G



CONNECTING CAM BOLT
 PART # 212
 (14)

H



ROLLER WHEELS
 PART # 788
 (8)

I



8mm WOOD DOWEL PINS
 PART # 307
 (8)

J



DELUXE WRIST REST / PAPER STOP
 PART # 354
 (1)

K



PLASTIC BUMPER
 PART # 786
 (2)

2 BEGIN ASSEMBLY BY INSTALLING HARDWARE AS SHOWN BELOW.

- The LETTERS next to the hardware shown refer to the same letters next to the hardware in the Parts List.
- When installing CAM BOLTS, be sure to tighten until shoulder rests on panel surface, as shown in FIG. C. Cams are inserted with CAM ARROWS pointing to the corresponding edge with the edge hole.

FIG. C

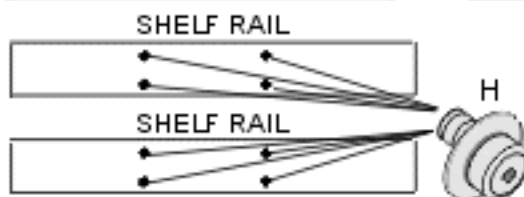
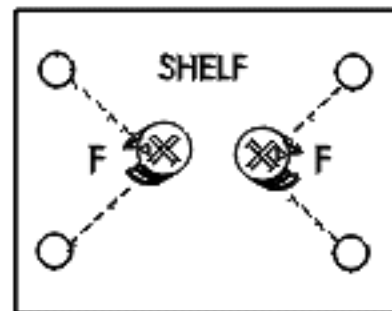
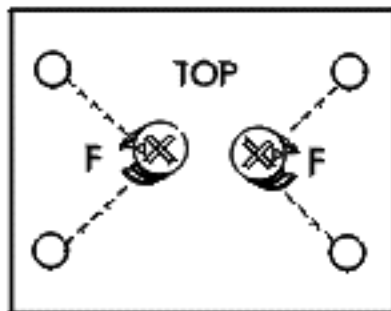
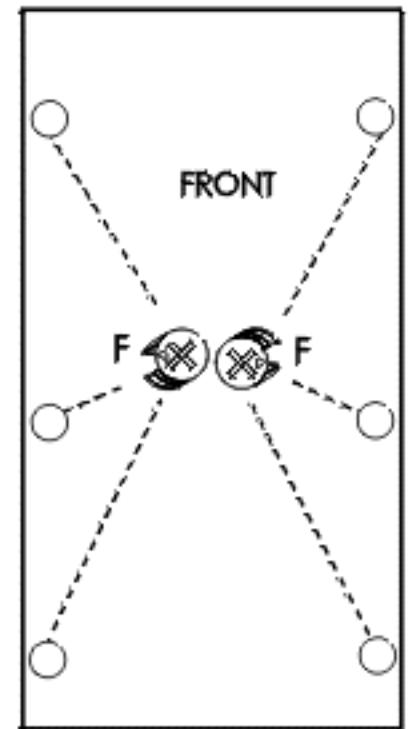
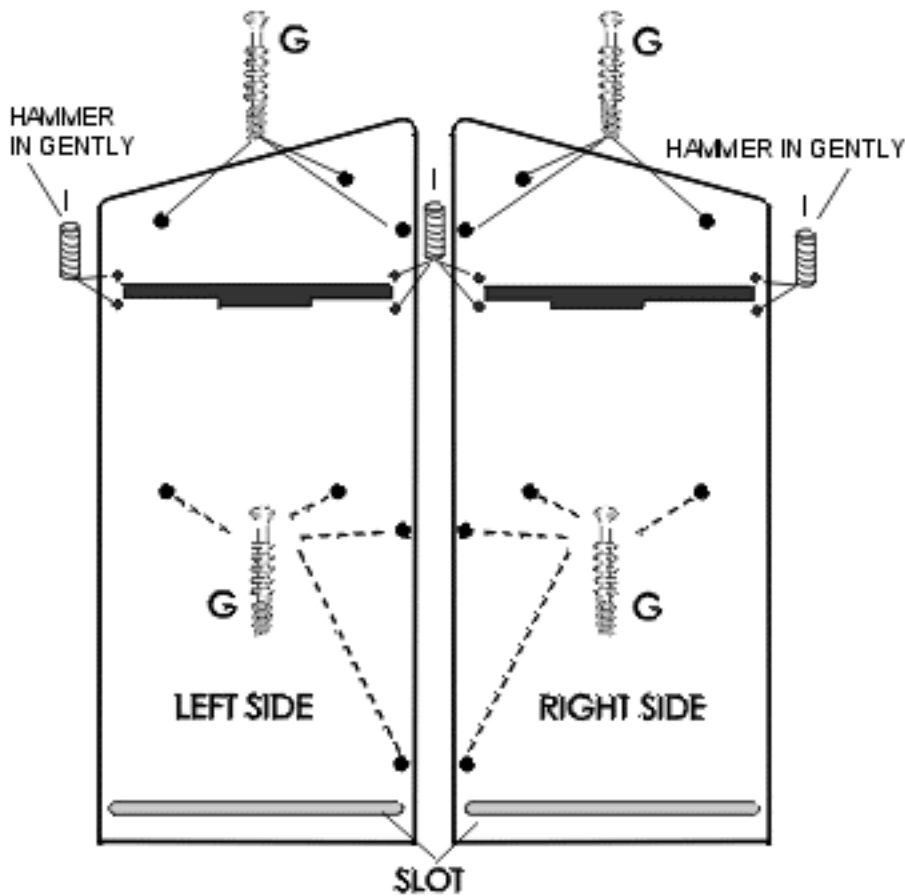
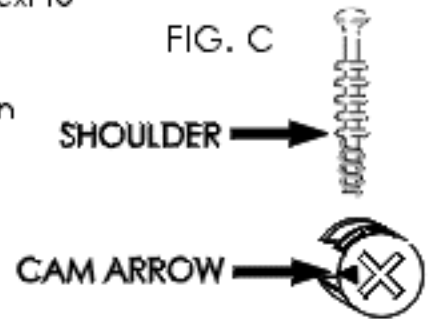

HAMMER IN GENTLY

(4) ROLLER WHEELS PER SHELF RAIL

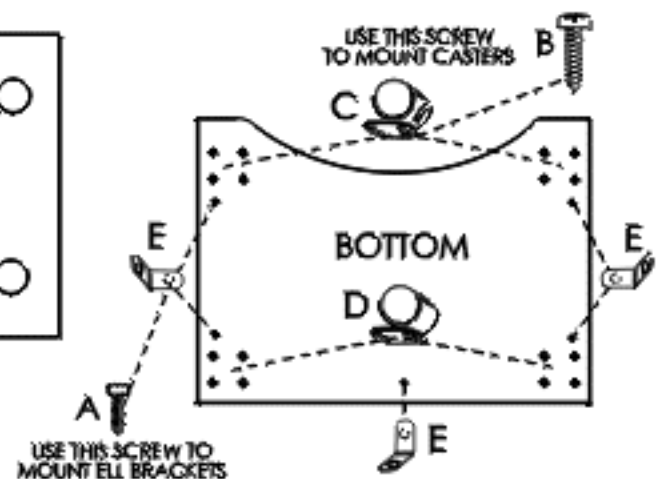

3 ASSEMBLY OF CABINET

NOTE: THE ARROW ON THE CAM MUST POINT TO THE CAM BOLT AS PANELS ARE ALIGNED FOR FASTENING. DO NOT PUT STRESS ON VERTICAL PANELS DURING ASSEMBLY. KEEP PANELS SUPPORTED DURING FASTENING. WHENEVER POSSIBLE, USE 2 PEOPLE FOR ASSEMBLY.

Lay LEFT SIDE down with CAM BOLTS facing up. With unfinished edges to the bottom, align and attach FRONT to LEFT SIDE as shown in FIG. 1. Tighten CAMS.

Align and attach (2) SHELF RAILS to WOOD DOWEL PINS on LEFT SIDE as shown. Push SHELF RAILS down onto DOWEL PINS until they are tight against panel. NOTE: ROLLER WHEELS on SHELF RAILS face each other.

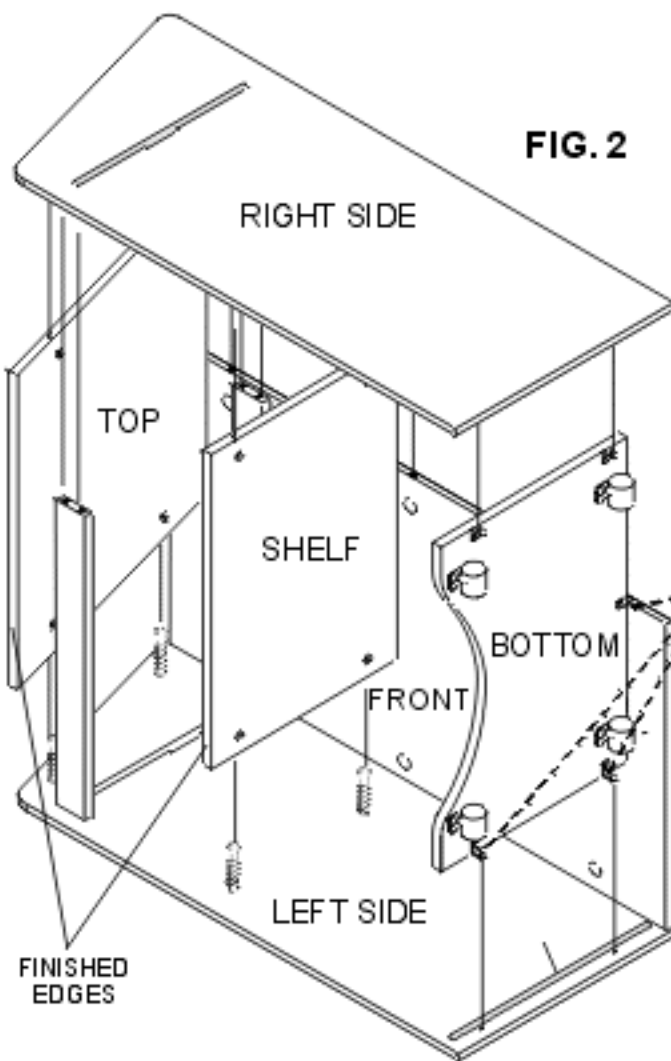
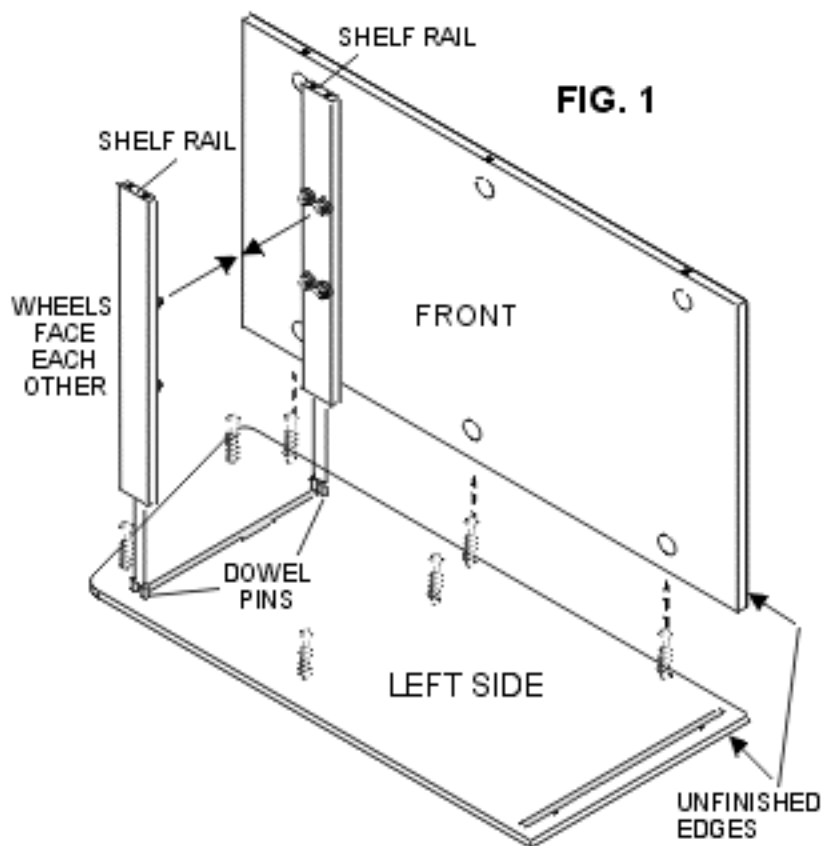

Align and attach TOP and SHELF to LEFT SIDE as shown. FIG. 2. NOTE: CAMS face bottom as shown. Tighten CAMS. Align and insert BOTTOM into slot in LEFT SIDE, with cut-out shape on BOTTOM facing away from FRONT.

Align and attach ELL BRACKETS on BOTTOM to LEFT SIDE using SCREWS A.

Align and attach RIGHT SIDE to TOP, SHELF, BOTTOM, FRONT and BRACES to DOWEL PINS. FIG. 2. Tighten CAMS.

Working under RIGHT SIDE, attach ELL BRACKETS on BOTTOM to RIGHT SIDE and FRONT using SCREWS A as shown.

Using 2 people, stand LECTERN upright onto casters, as shown below.

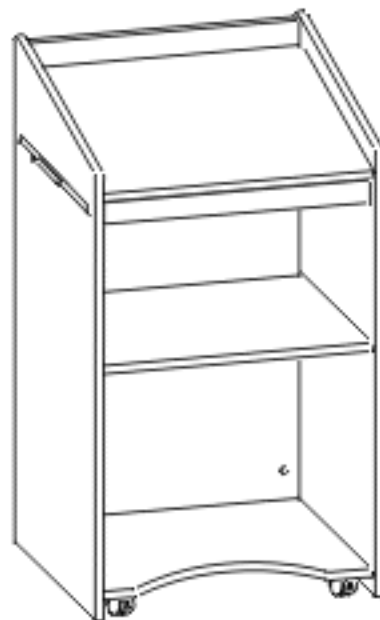

4 INSTALL SLIDING SHELF

Align and insert SLIDING SHELF into cut-out in LEFT SIDE as shown FIG. 3. **INSURE** that the lot label faces down and is to the front of the unit.

SLIDING SHELF must engage between ROLLER WHEELS on SHELF RAILS.

With SLIDING SHELF installed completely between LEFT and RIGHT SIDES, install PLASTIC BUMPERS (2) into holes underneath. FIG. 4. Hammer in gently until seated against bottom of SHELF.

SLIDING SHELF may be accessed either to the LEFT or RIGHT hand side, by pushing it through one side and pulling it out of the other.

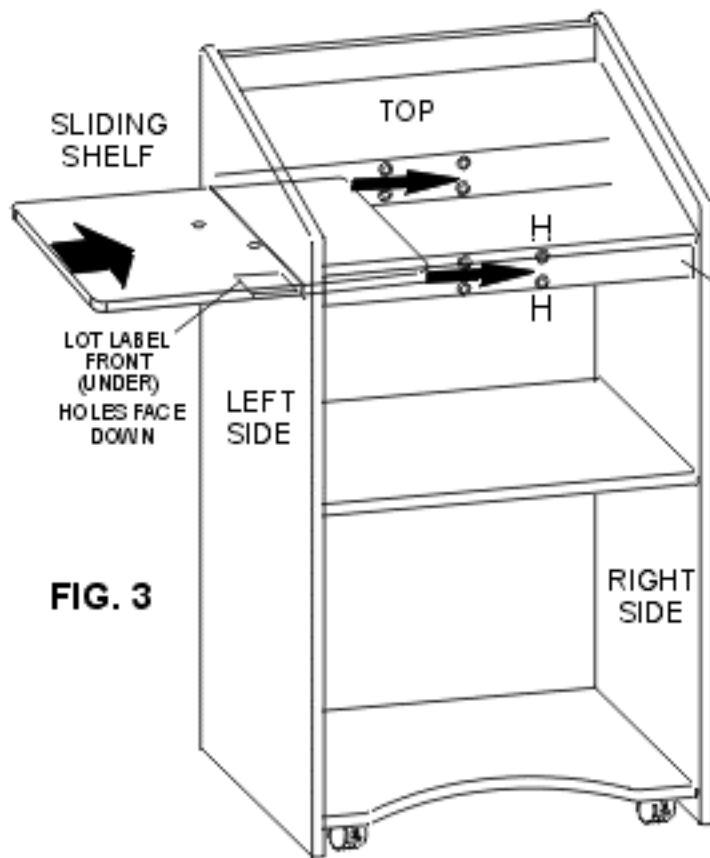

FIG. 3

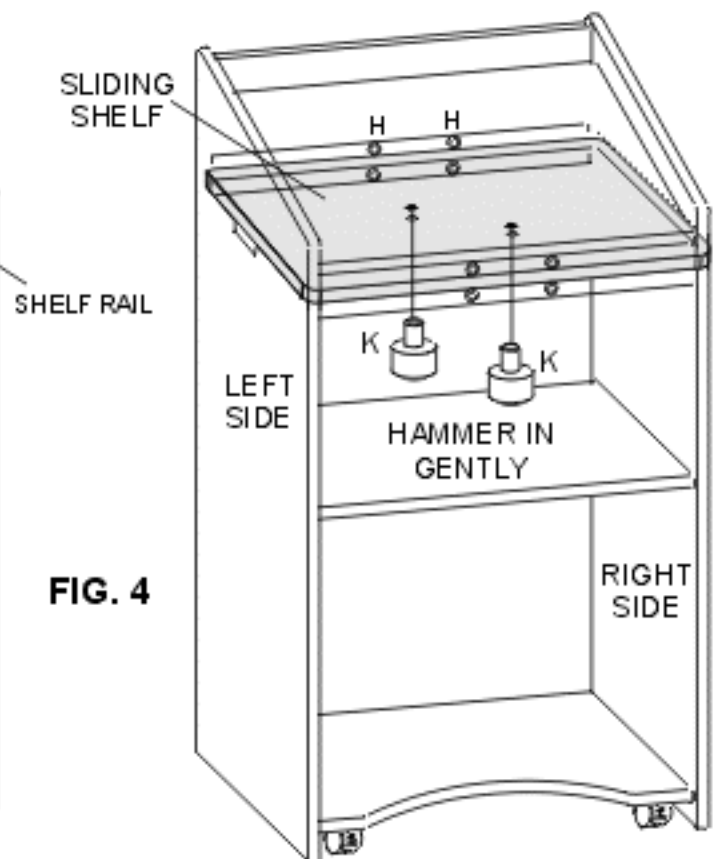

FIG. 4

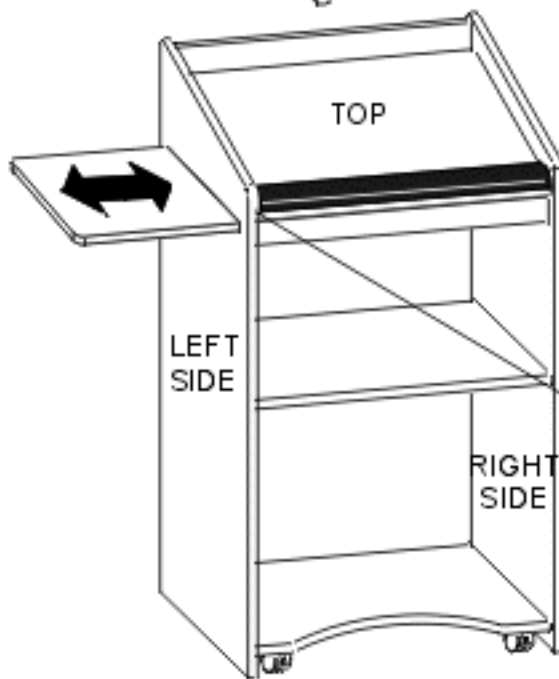

FIG. 5

BLACK PAPER STOP
J

NOTE: CARE MUST BE TAKEN IN POSITIONING WRIST REST. ONCE ADHESIVE IS ACTIVATED, WRIST REST MAY NOT BE REPOSITIONED.

REMOVE PAPER LINER

5 INSTALL WRIST REST / PAPER STOP

Remove paper liner from adhesive strip on the back of WRIST REST / PAPER STOP (J). FIG. 5. Carefully align WRIST REST / PAPER STOP along front edge of TOP - centering it from side to side. Press PAPER STOP onto TOP to secure