

# Vertiflex™ Products

## ONE PIECE FLOOR LECTERN

### ASSEMBLY INSTRUCTIONS

50051C OAK  
50052C WALNUT  
50265C MAHOGANY

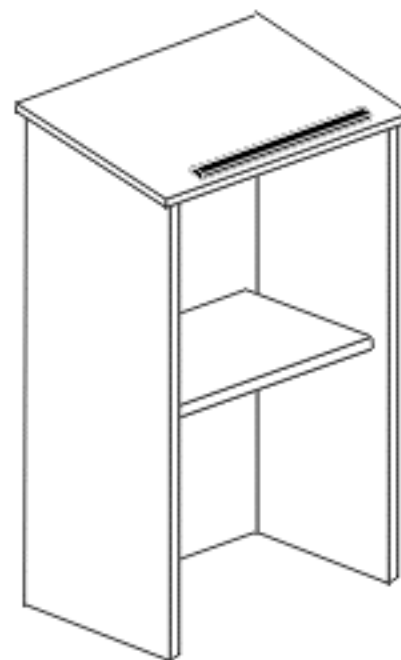

- Use caution during assembly, unbanded edges can be sharp and may chip if mishandled.
- Remove staples, (if any) from carton and use carton to set parts on during assembly.
- Page two of this instruction sheet contains an illustrated parts list and phone number to call in case of missing hardware. The parts list also contains drawings of the screws and other hardware as an easy identification guide.

### TOOLS REQUIRED

#2 PHILLIPS SCREWDRIVER - CAMBOLT  
#6 FLAT SCREWDRIVER - CAM  
HAMMER - NAIL-ON GLIDES

POWER TOOLS ARE NOT RECOMMENDED

### CAM LOCK ASSEMBLY

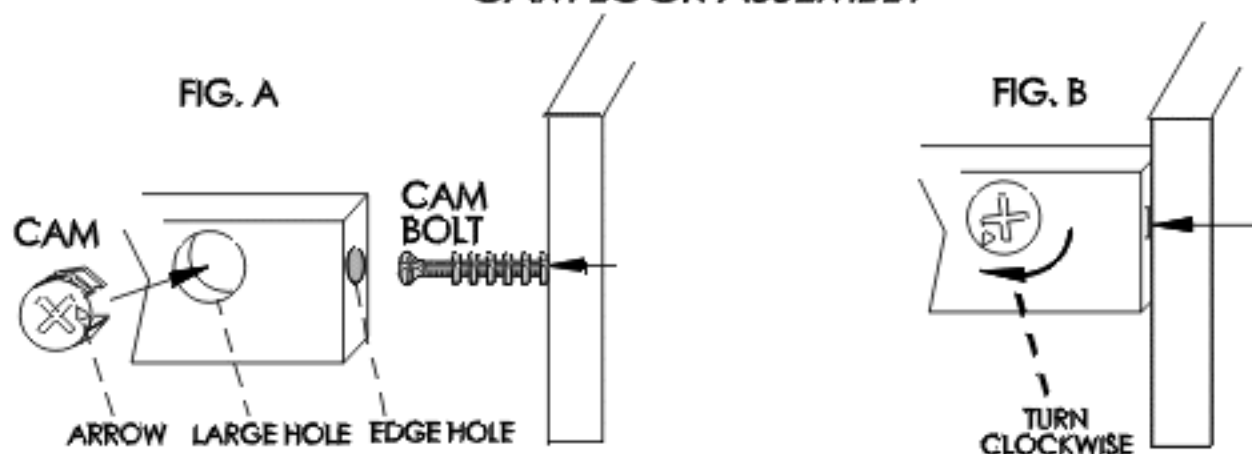

- Insert CAM, with arrow pointing to edge hole, into large hole in face of panel as shown in FIG. A
- Fully insert CAM BOLT, installed on adjoining panel, into edge hole as shown in FIG. A and FIG. B
- Turn CAM clockwise 1/3 rotation to lock panels together. SEE FIG. B. For additional security, CAM may be turned another 1/4 turn.

# 1. IDENTIFY ALL PARTS.

If any parts are missing OR you have questions about assembly, please call  
 CUSTOMER SERVICE 1-800-966-5511 Monday - Friday 8am. TO 4:30pm. (Central)

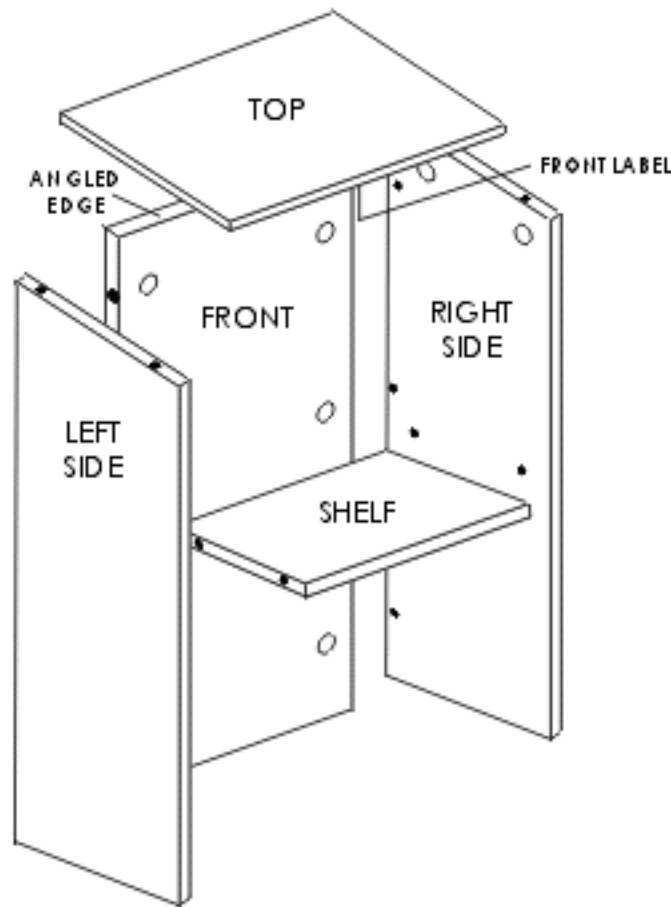

## IDENTIFY PARTS FROM SIZE LISTING BELOW

NO.	WOOD PART LIST	WOOD PART SIZES		WOOD PART NUMBERS BY COLOR		
		WIDTH	LENGTH	OAK	WALNUT	MAHOGANY
1	FRONT	20-7/16"	X 45"	51COAK-FRONT	52CWAL-FRONT	265CMAH-FRNT
1	LEFT SIDE	14-5/8"	X 45-3/8"	51COAK-LSIDE	52CWAL-LSIDE	265CMAH-LSID
1	RIGHT SIDE	14-5/8"	X 45-3/8"	51COAK-RSIDE	52CWAL-RSIDE	265CMAH-RSID
1	SHELF	11-7/8"	X 20-7/16"	51COAK-SHELF	52CWAL-SHELF	265CMAH-SHLF
1	TOP	15-3/4"	X 23"	51COAK-TOP	52CWAL-TOP	265CMAH-TOP

## HARDWARE

A



19mm CAM  
 PART# 213  
 (14)

B



CONNECTING CAM  
 BOLT  
 PART# 212  
 (14)

C



RECTANGULAR TACK GLIDE  
 PART# 215  
 (4)

PAPER STOP  
 PART# 793  
 (1)



NOT TO SCALE

## 2 BEGIN ASSEMBLY BY INSTALLING HARDWARE AS SHOWN BELOW.

- The LETTERS next to the hardware shown refer to the same letters next to the hardware in the Parts List.
- When installing CAM BOLTS, be sure to tighten until shoulder rests on panel surface, as shown in FIG. C. Cams are inserted with CAM ARROWS pointing to the corresponding edge with the edge hole.

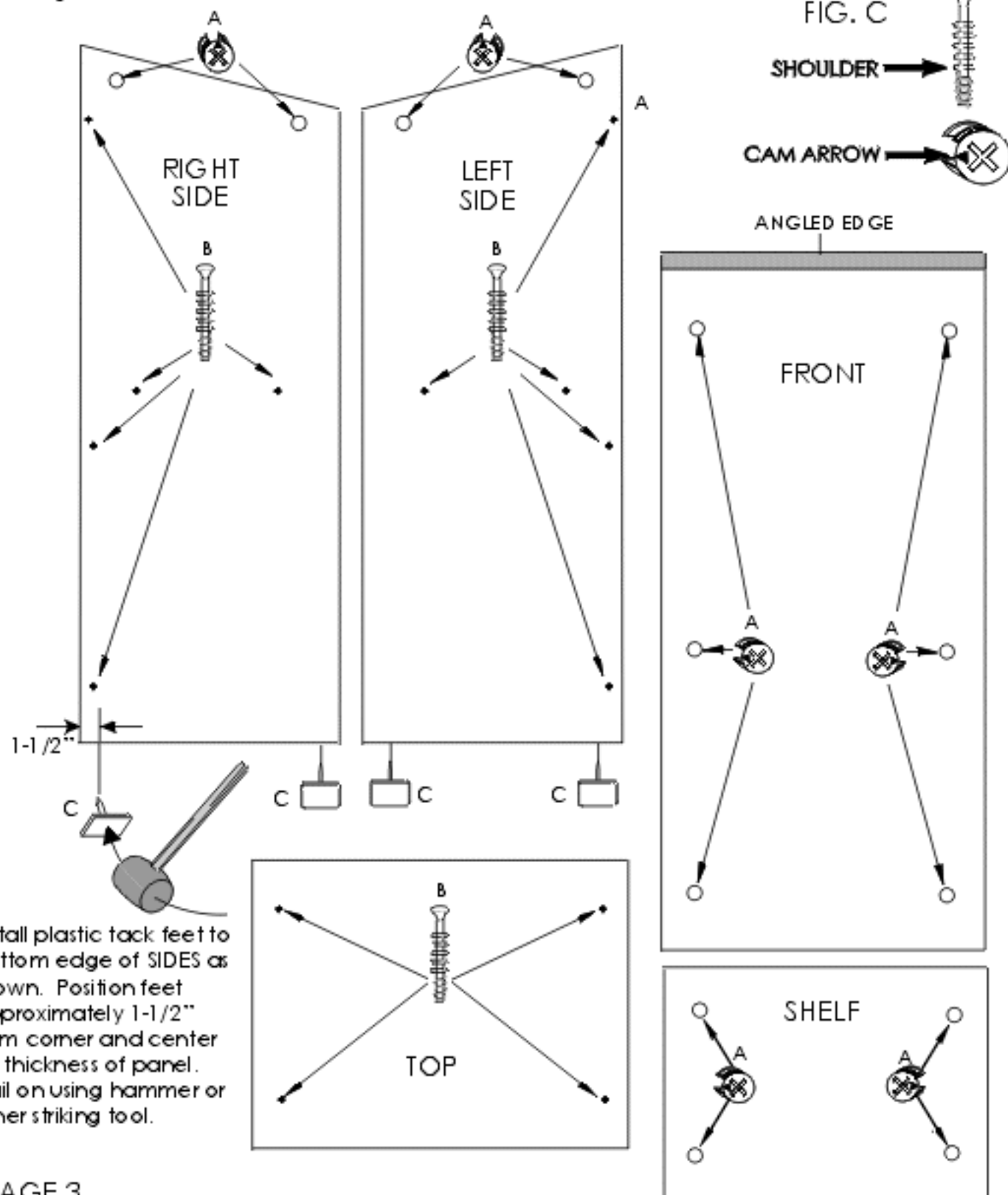

### 3 ASSEMBLY OF CABINET

NOTE: THE ARROW ON THE CAM MUST POINT TO THE CAM BOLT AS PANELS ARE ALIGNED FOR FASTENING. DO NOT PUT STRESS ON VERTICAL PANELS DURING ASSEMBLY. KEEP PANELS SUPPORTED DURING FASTENING. WHEN POSSIBLE, USE 2 PEOPLE FOR A SSEMBLY.

- Lay RIGHT SIDE on a flat surface, protecting surface from scratches, as shown in FIG. D; CAM BOLTS FACING UP.
- Align and attach FRONT and SHELF to RIGHT SIDE as shown. Tighten all CAMS.

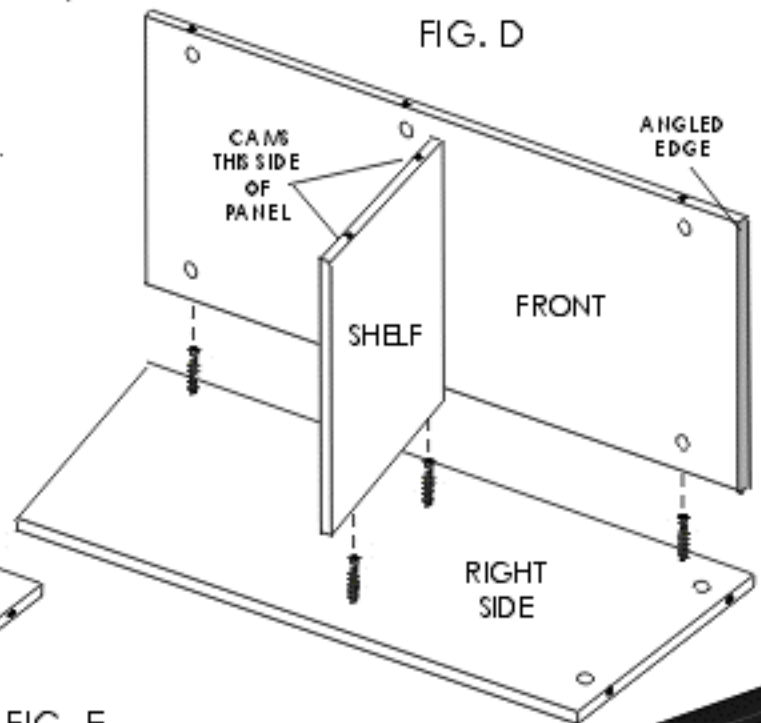
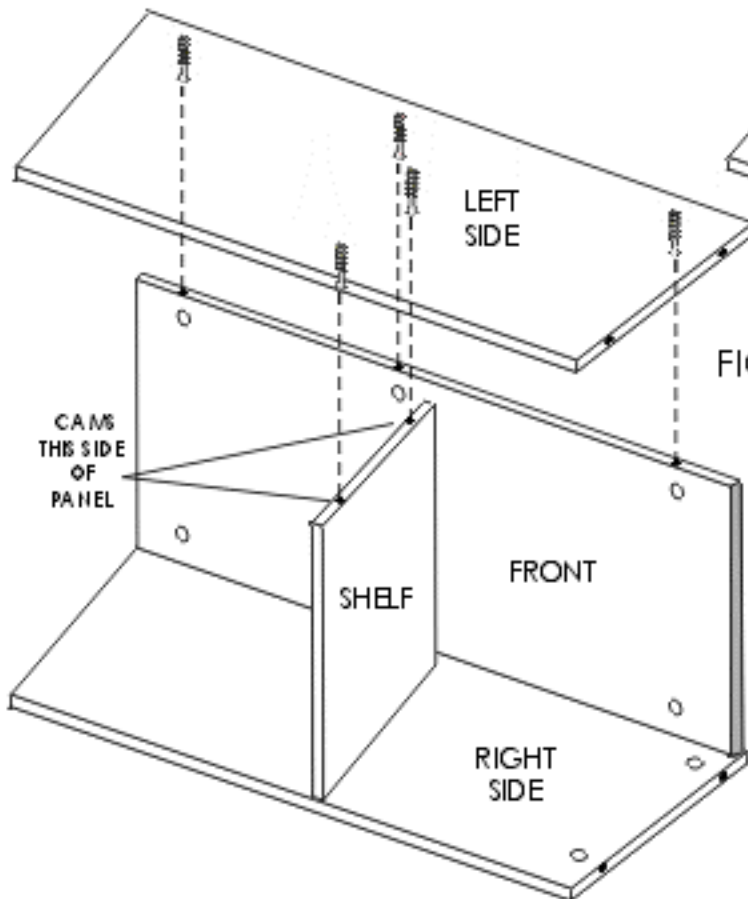

FIG. E



WRIST REST / PAPER STOP

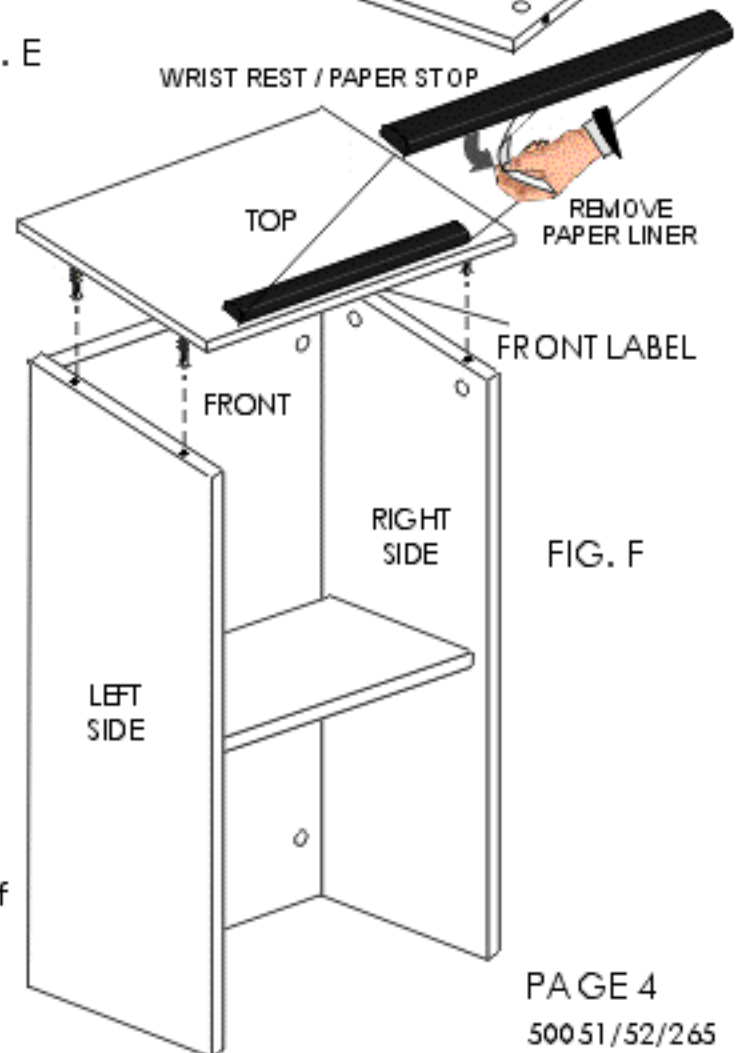

FIG. F

- Align and attach LEFT SIDE to FRONT and SHELF as shown in FIG. E. Tighten all CAMS.
- Using 2 people, stand unit upright on to sides as shown in FIG. F. NOTE: FRONT LABEL. Align and attach TOP to SIDES. Tighten CAMS.
- Remove paper liner from adhesive on back of WRIST REST / PAPER STOP. Carefully align PAPER STOP along front edge of TOP - centering it from side to side. Press PAPER STOP on to TOP to secure.

PAGE 4  
50051/52/265