

# Vertiflex™ Products

## AUDIOVISUAL CART- LECTERN BASE

### ASSEMBLY INSTRUCTIONS

50060C OAK  
50061C WALNUT  
50267C MAHOGANY

#### NOTES ON ASSEMBLY

- Use caution during assembly, unbanded edges can be sharp and may chip if mishandled.
- Remove staples, (if any) from carton and use carton to set parts on during assembly.
- Page two of this instruction sheet contains an illustrated parts list and phone number to call in case of missing hardware. The parts list also contains drawings of the screws and other hardware as an easy identification guide.

#### TOOLS REQUIRED

#2 PHILIPS SCREWDRIVER – CAM BOLT  
#6 FLAT SCREWDRIVER – CAM  
HAMMER

POWER TOOLS ARE NOT RECOMMENDED

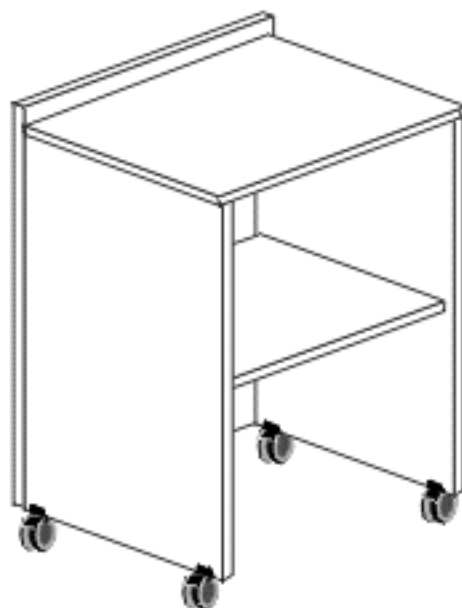

#### CAM LOCK ASSEMBLY

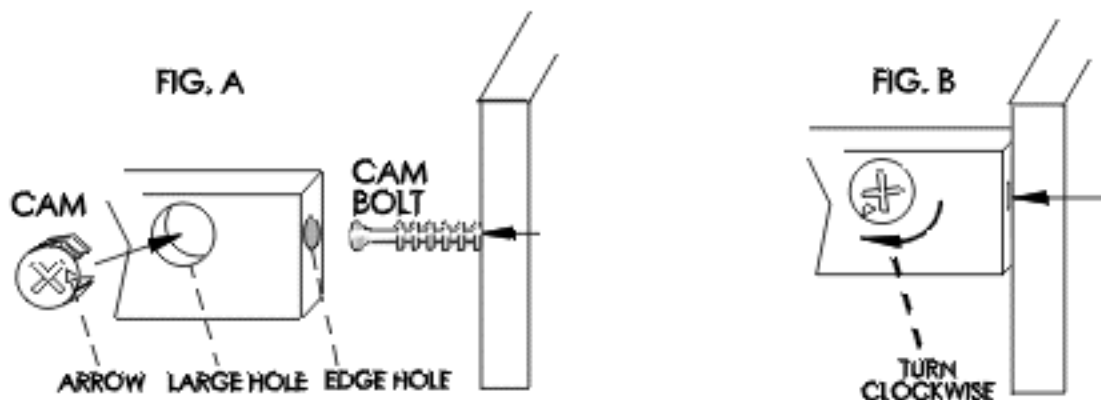

- Insert CAM, with arrow pointing to edge hole, into large hole in face of panel as shown in FIG. A
- Fully insert CAM BOLT, installed on adjoining panel, into edge hole as shown in FIG. A and FIG. B
- Turn CAM clockwise 1/3 rotation to lock panels together. FIG. B. For additional security, CAM may be turned another 1/4 turn.

PAGE 1

50060-61-267

# 1. IDENTIFY ALL PARTS.

If any parts are missing OR you have questions about assembly, please call  
 CUSTOMER SERVICE 1-800-966-5511 Monday - Friday 8am. TO 4:30pm (Central)

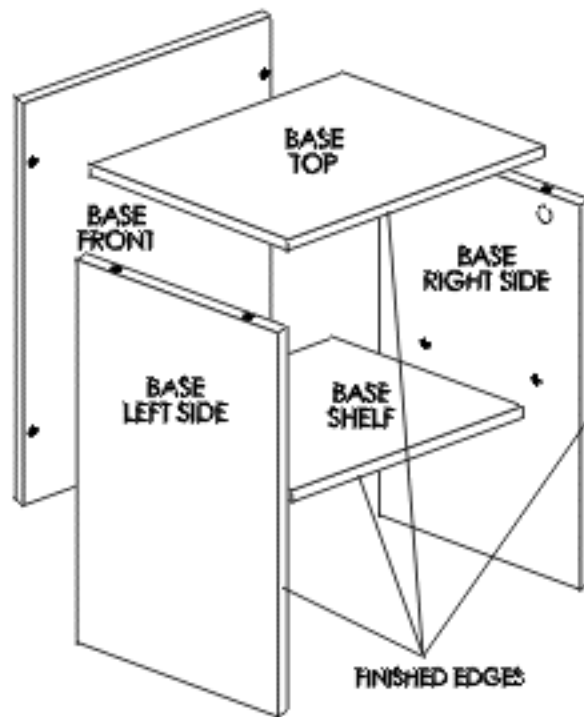

IDENTIFY PARTS FROM  
 SIZE LISTING BELOW

NO.	WOOD PART LIST	WOOD PART SIZES		WOOD PART NUMBERS BY COLOR		
		WIDTH	LENGTH	OAK	WALNUT	MAHOGANY
1	FRONT	21-1/8"	X 31-3/4"	60C OAK-FRONT	61CWAL-FRONT	267C MAH-FRNT
1	LEFT SIDE	16-3/4"	X 30-1/4"	60C OAK-LSIDE	61CWAL-LSIDE	267C MAH-LSID
1	RIGHT SIDE	16-3/4"	X 30-1/4"	60C OAK-R SIDE	61CWAL-RSIDE	267C MAH-R SID
1	SHELF	15-3/4"	X 19-1/2"	60C OAK-SHELF	61CWAL-SHELF	267C MAH-SHLF
1	TOP	16-3/4"	X 21-1/8"	60C OAK-TOP	61CWAL-TOP	267C MAH-TOP

A



CASTER  
 SOCKETS  
 PART # 214  
 (4)

B

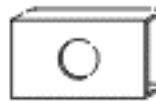

3/4" "U"  
 BRACKETS  
 PART # 517  
 (4)

C



CASTER  
 NON-LOCKING  
 PART # 520  
 (2)



CASTER  
 LOCKING  
 PART # 519  
 (2)

D



CONNECTING CAM  
 BOLT  
 PART # 212  
 (12)

E



19mm CAM  
 PART # 213  
 (12)

## 2 BEGIN ASSEMBLY BY INSTALLING HARDWARE AS SHOWN BELOW.

- The LETTERS next to the hardware shown refer to the same letters next to the hardware in the Parts List.
- When installing CAM BOLTS, be sure to tighten until shoulder rests on panel surface, as shown in FIG. C. Cams are inserted with CAM ARROWS pointing to the corresponding edge with the edge hole.

FIG. C

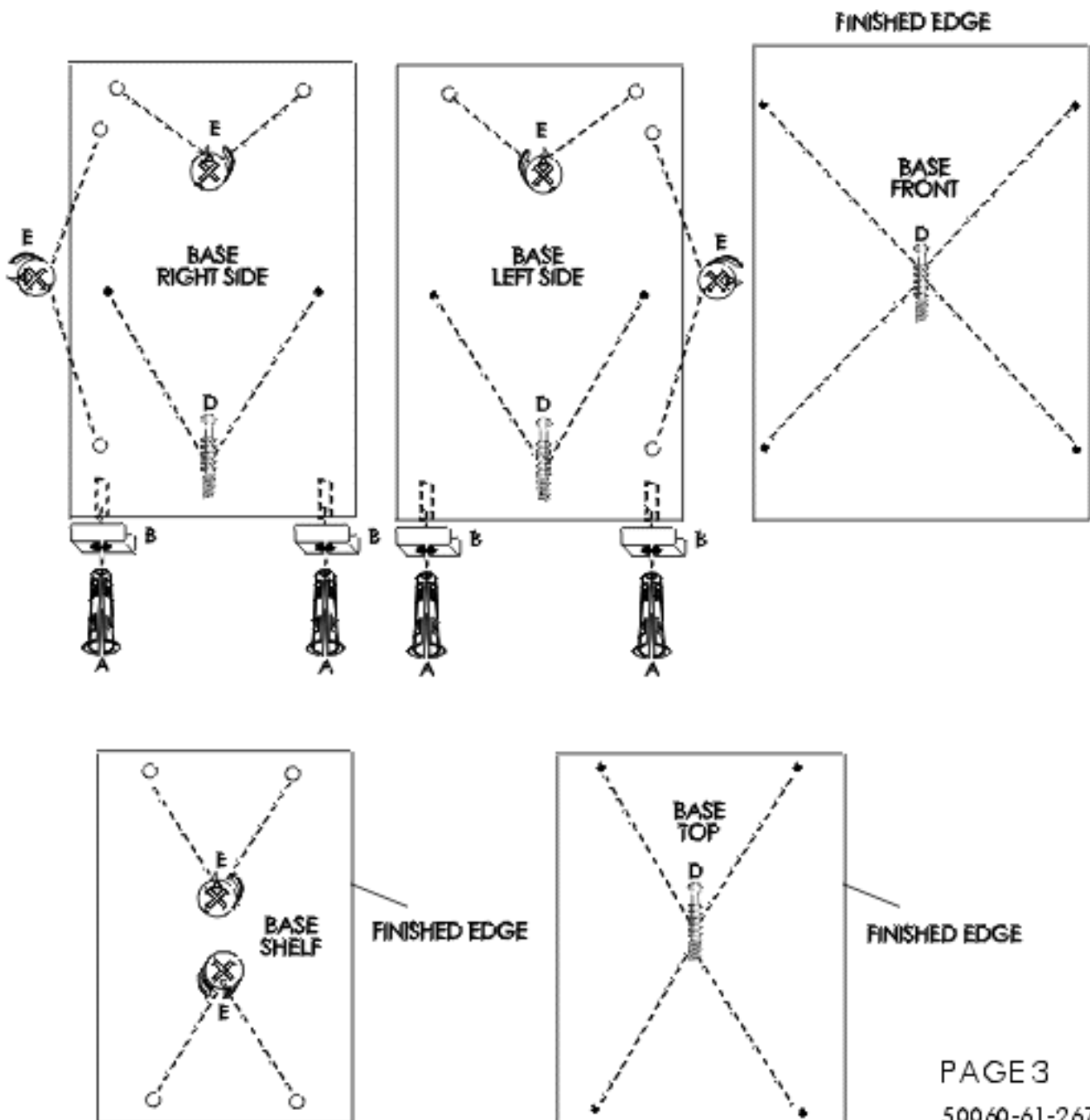
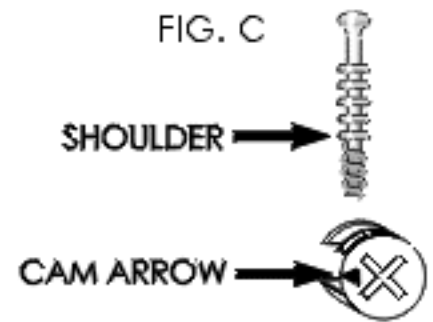

### 3 ASSEMBLY OF CABINET

- **NOTE:** THE ARROW ON THE CAM MUST POINT TO THE CAM BOLT AS PANELS ARE ALIGNED FOR FASTENING. DO NOT PUT STRESS ON VERTICAL PANELS DURING ASSEMBLY. KEEP PANELS SUPPORTED DURING FASTENING. WHEN POSSIBLE, USE 2 PEOPLE FOR ASSEMBLY.

- Align and attach **BASE RIGHT SIDE** TO **BASE SHELF** as shown in FIG. D. **NOTE:** ALL finished edges face the floor. Tighten CAMS. Align and attach **BASE LEFT SIDE** to **BASE SHELF**. Tighten CAMS.

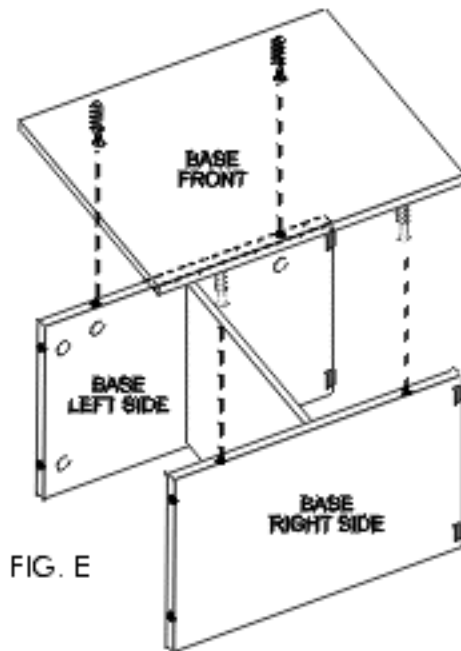
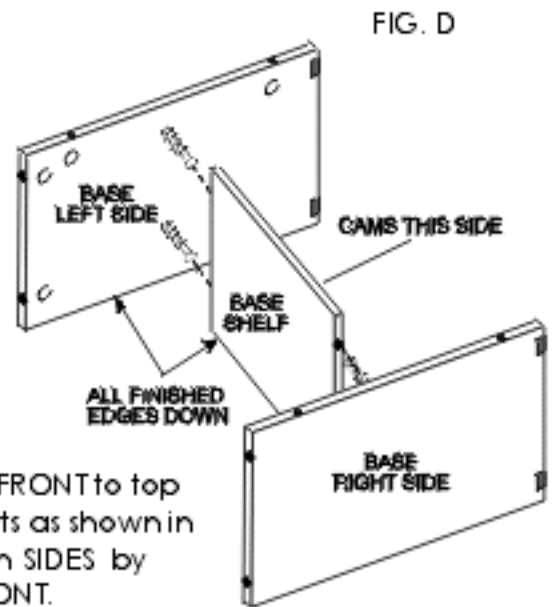

FIG. E

- Align and attach **BASE FRONT** to top edge of assembled parts as shown in FIG. E. Tighten CAMS on SIDES by working under **BASE FRONT**.

- Align and attach (4) **CASTERS** to bottom edge of **SIDES** by pushing **CASTER** stem into socket until it "clicks" into position, as shown in FIG. F

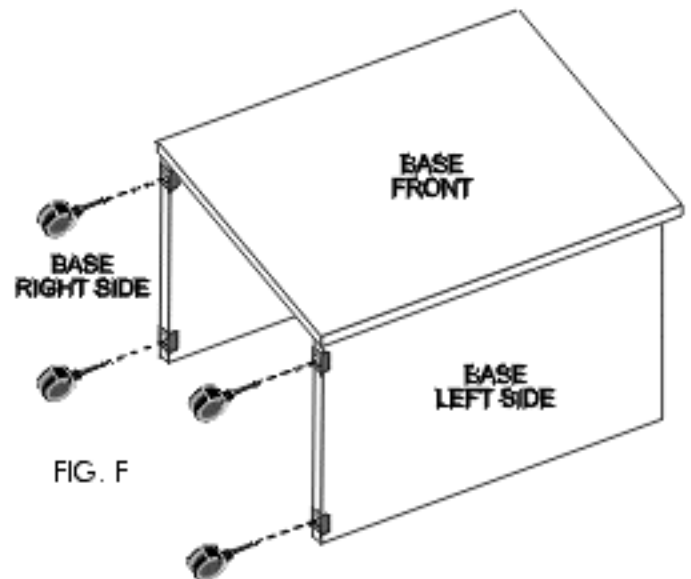

FIG. F

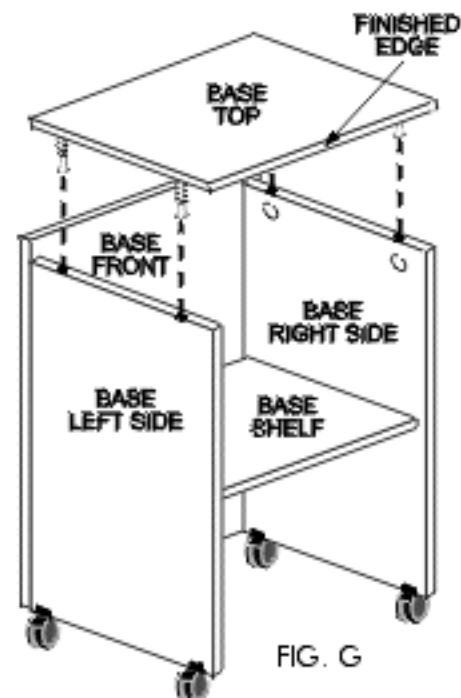

FIG. G

- Using 2 people, stand assembled parts up onto **CASTERS** as shown in FIG. G. Align and attach **BASE TOP** to **SIDES**. **NOTE:** Finished edge on **BASE TOP** faces out. Tighten CAMS.

**NOTE:** If Table Top Lectern has been purchased for use with this unit, attach the 2 units together as shown in FIG. H.

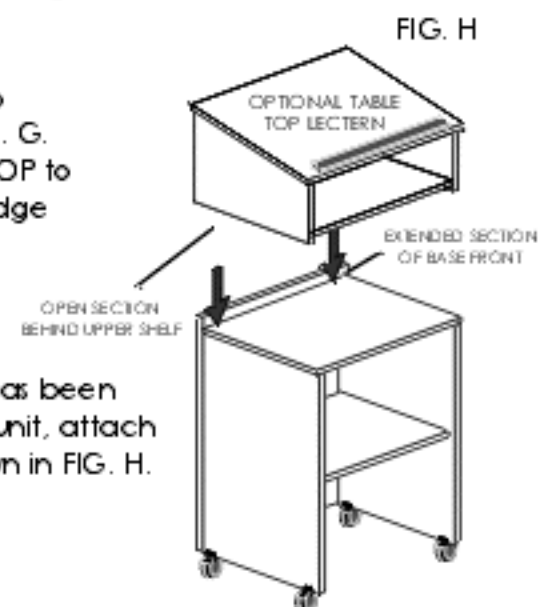

FIG. H