

# File Rover with open top

VF50356 (black) • VF50432 (medium oak)

Vertiflex  
Products™

Assembly Instructions

www.advantus.com

904.482.0091

## General Instructions

To facilitate the assembly of this product, special fittings have been pre-mounted on some panels. After installation of SHOULDER SCREWS onto the edges of some panels, all that is needed to fasten the panels is to match the male and female fittings, tap the panels gently to insure a good fit and turn the Phillips head on the female fitting clockwise, using a Phillips screwdriver. If the panels need to be taken apart, simply reverse the procedure. Care must be taken, however, so as not to damage the fittings.

SHOULDER SCREWS (male fittings) mounted on the edges of the panels are NOT CENTERED (See figure below). The portion which has the shortest distance to the edge of the panel MUST be adjacent to the Phillips screw head on the female fitting.

### Tools Required:

- #2 Phillips Screwdriver - Cam Bolt
- #6 Flat Screwdriver - Cam
- Hammer

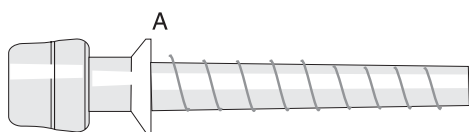
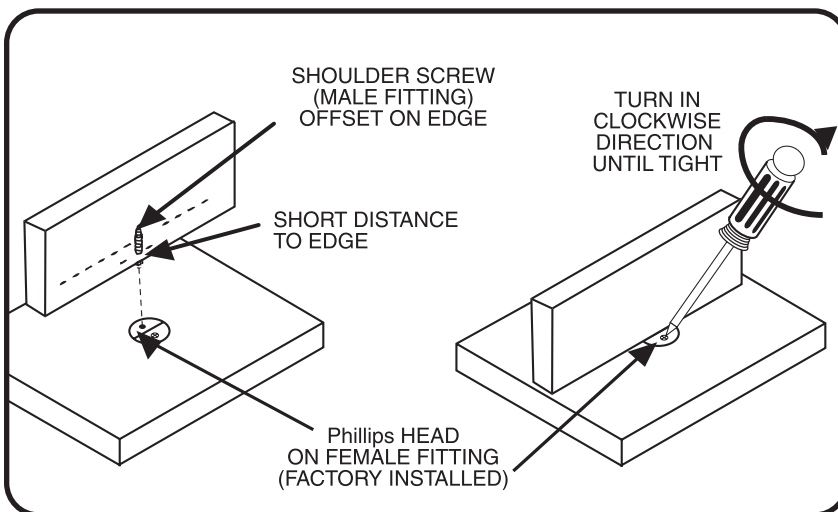
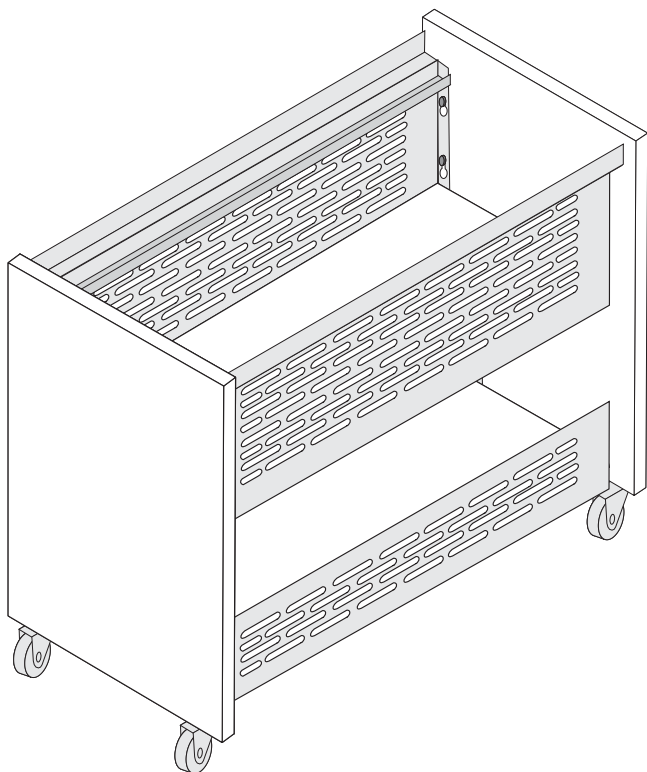

SHOULDER SCREW  
(8)

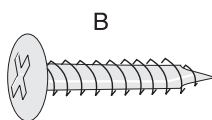

#8 x 5/8"  
TRUSS HEAD  
SCREW - BLACK  
(18)

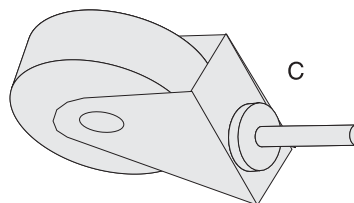

CASTER  
(4)



CASTER  
SOCKET  
(4)

# 1

## Hardware & Parts List

Identify all parts from diagram and size listing below.

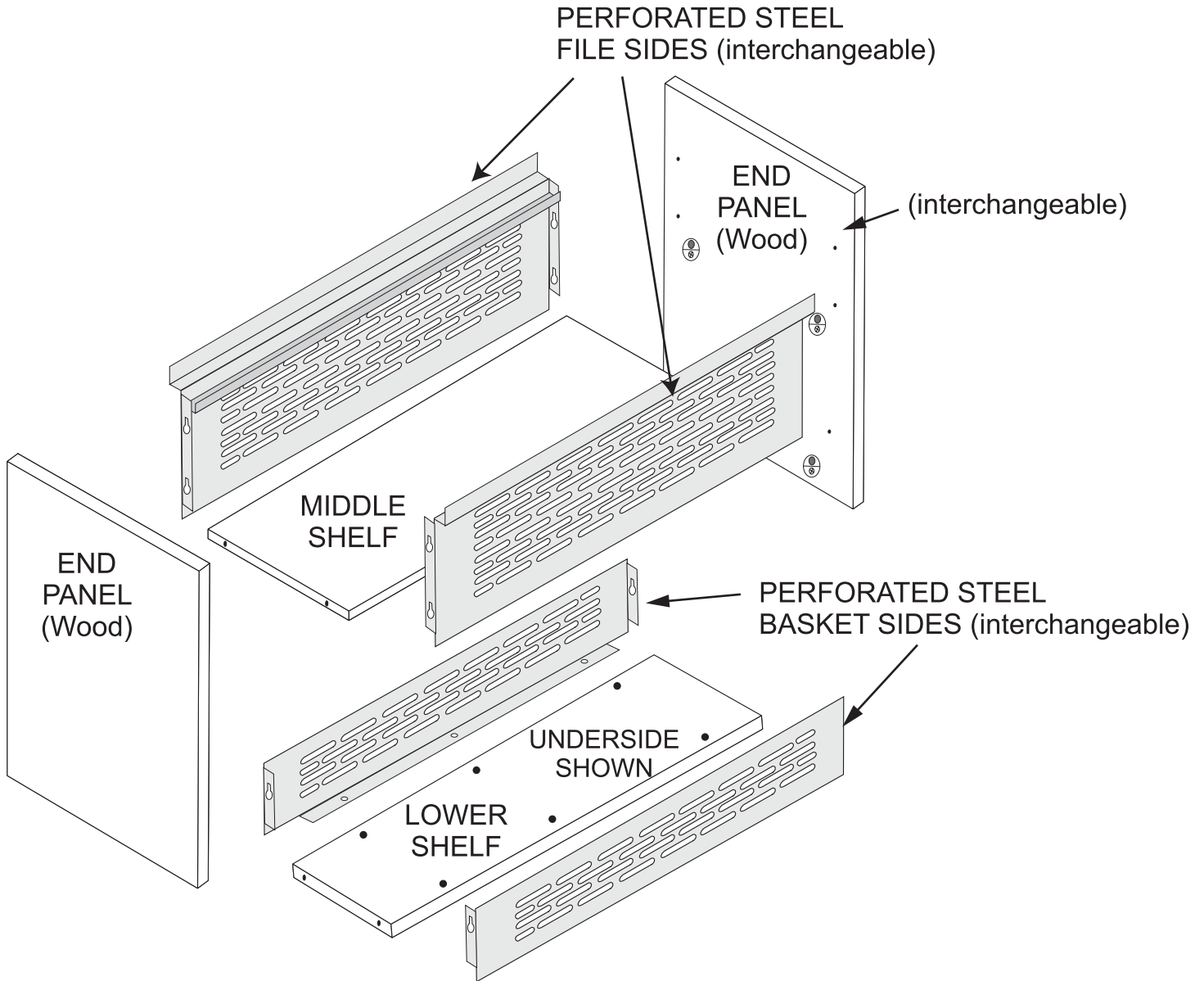

WOOD PART LIST		WOOD PART SIZES				IDENTIFIER	
QTY	NAME	THICK		WIDTH		LENGTH	
2	END PANEL	3/4"	X	14-3/4"	X	24-1/4"	BY SIZE, INSTALLED FITTINGS
1	LOWER SHELF	3/4"	X	12-3/4"	X	24-11/16"	BY SIZE, 6 FACE HOLES
1	MIDDLE SHELF	3/4"	X	13-3/8"	X	24-11/16"	BY SIZE, NO FACE DRILLING
2	BASKET SIDE (STEEL)		X	4"	X	24-11/16"	BY SIZE, NOTE ILLUSTRATION
2	FILE SIDE (STEEL)		X	11-3/4"	X	24-11/16"	BY SIZE, NOTE ILLUSTRATION

# 2

## Install Hardware

**USE HARDWARE LIST TO IDENTIFY ALL PARTS**

Lay MIDDLE SHELF and LOWER SHELF on a flat, non-scratch surface. FIG. 2 Install (4) SHOULDER SCREWS (A) each in edges as shown. DO NOT OVER-TIGHTEN. Gently TAP (2) CASTER SOCKETS (J) each into holes in bottom edge of END PANELS. FIG.2A

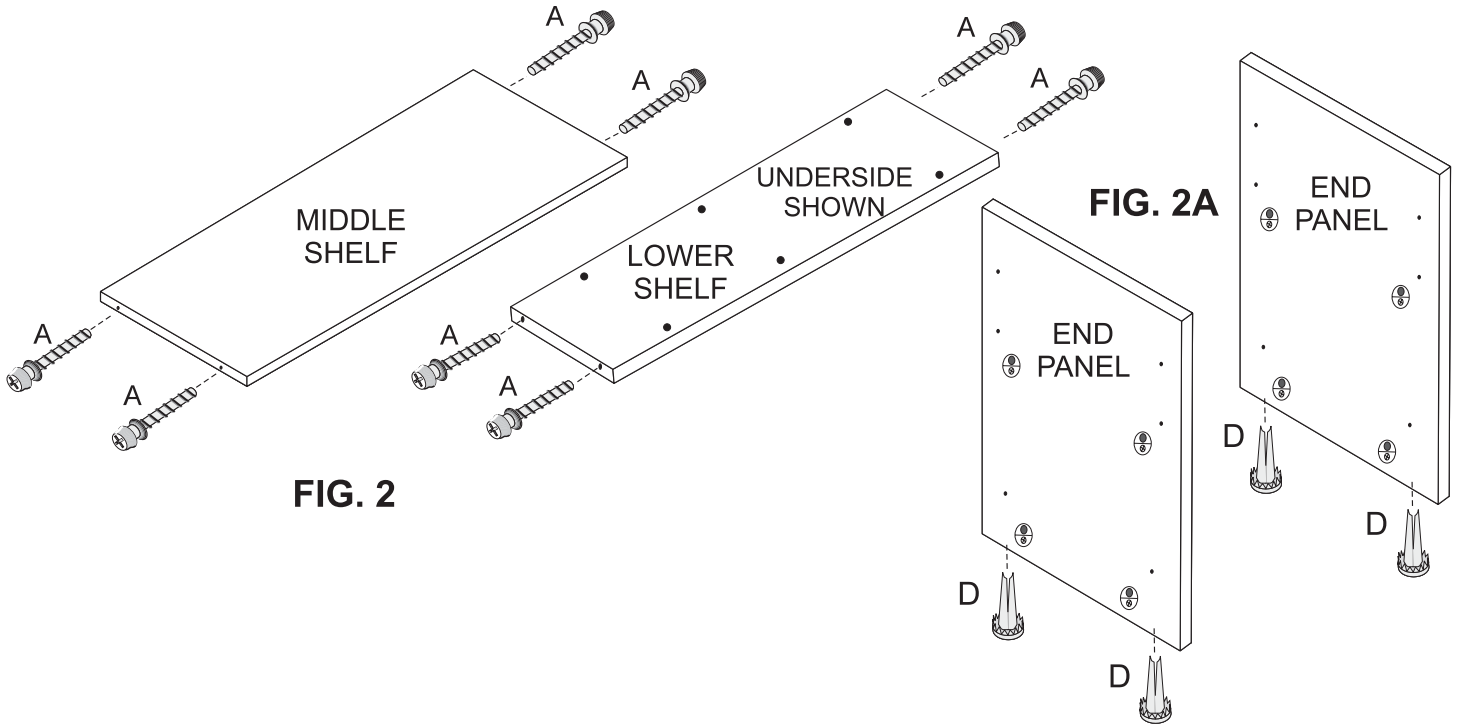

# 3

## Assemble

Lay END PANEL on a flat, non-scratch surface, assembly fittings facing up. FIG.3 Align and attach MIDDLE SHELF to fittings near middle of END PANEL, refer to page 1 on positioning of offset shoulder screws. Tighten fittings. Keeping face drilling as shown FIG.3, Align and attach LOWER SHELF to fittings near bottom edge of END PANEL. Tighten fittings. Align and attach fittings on END to shoulder screws on MIDDLE SHELF and LOWER SHELF as shown FIG.3A. Tighten all fittings from under side.

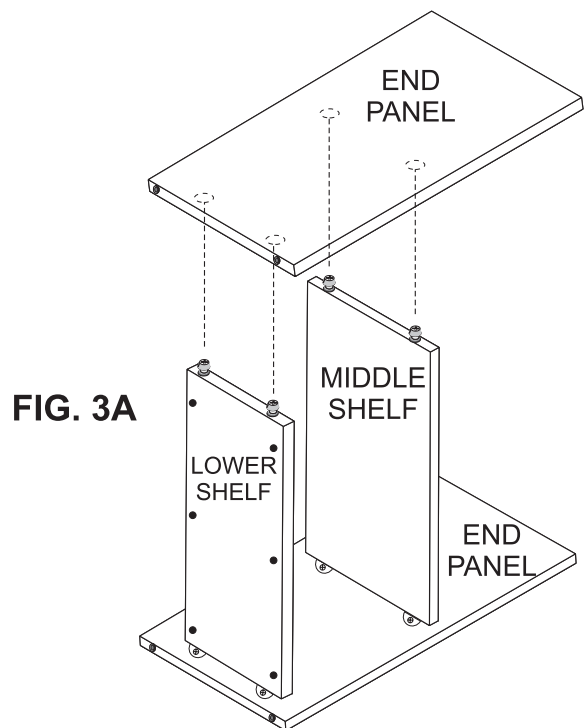
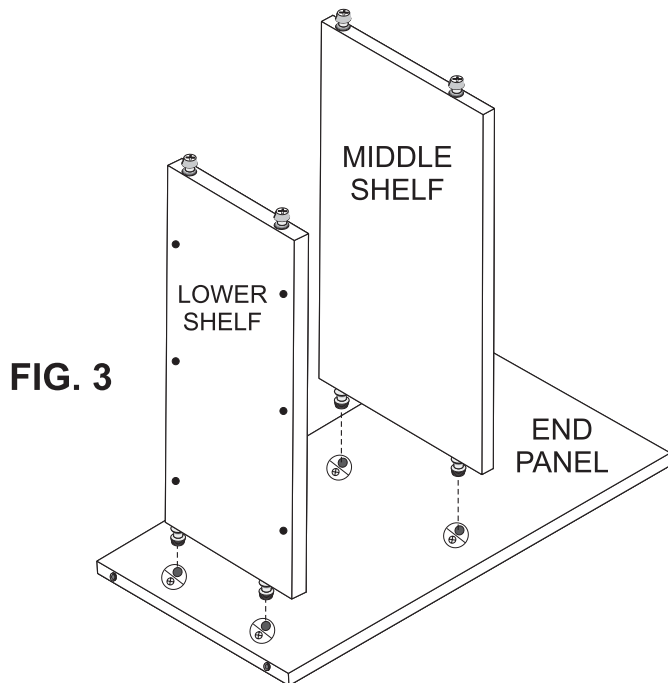

# 4 Assemble

**NOTE: BASKET SIDES ARE INTERCHANGEABLE**

Using 2 people, Carefully flip unit over to rest on top edges of END PANELS. Align and attach (2) PERFORATED STEEL BASKET SIDES to LOWER SHELF using (6) #8 x 5/8" TRUSS HEAD SCREWS (B) as shown FIG.4. Install (4) CASTERS (C) into CASTER SOCKETS, some force may be required to click into place. FIG.4 Using 2 people, Carefully flip unit over to rest on CASTERS. Complete BASKET SIDE assembly using (4) #8 x 5/8" TRUSS HEAD SCREWS (B) to fasten bent flanges to pre-drilled holes on faces of END PANELS.

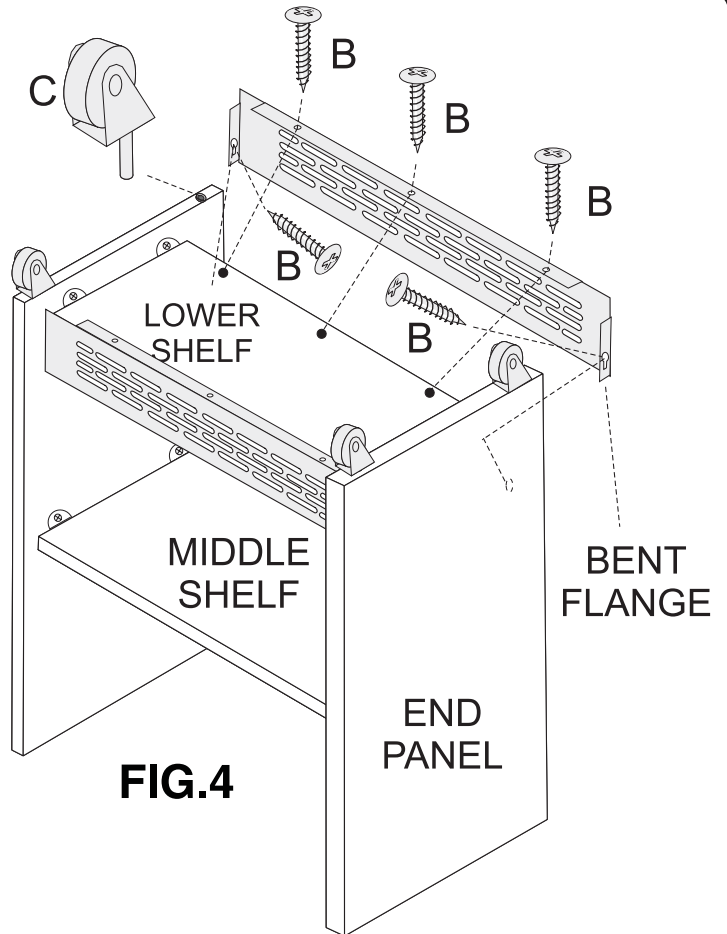

# 5 Assemble

**NOTE: FILE SIDES ARE INTERCHANGEABLE**

Align and attach (2) PERFORATED STEEL FILE SIDES to END PANELS using (8) #8 x 5/8" TRUSS HEAD SCREWS (B) as shown FIG.5. For proper installation bottom edge of FILE SIDES should rest on top surface of MIDDLE SHELF.

