

# Vertiflex™ Products

# STAND 'N VIEW

MODEL 110

ASSEMBLY INSTRUCTIONS

## GENERAL INSTRUCTIONS

To facilitate the assembly of this product, special fittings have been pre-mounted on some panels. After installation of **SHOULDER SCREWS** onto the edges of some panels, all that is needed to fasten the panels is to match the male and female fittings, tap the panels gently to insure a good fit and **turn the phillips head on the female fitting clockwise**, using a phillips screwdriver.

If the panels need to be taken apart, simply reverse the procedure. **Care must be taken, however, so as not to damage the fittings.**

## IMPORTANT

**SHOULDER SCREWS** (male fittings) mounted on the edges of the panels are **NOT CENTERED** (See figure below). The portion which has the shortest distance to the edge of the panel **MUST** be adjacent to the phillips screw head on the female fitting. To aid in assembly, parts have been stamped with an **ARROW** on the **EDGE** to indicate direction of this offset.



## TOOLS REQUIRED

#2 PHILLIPS SCREWDRIVER

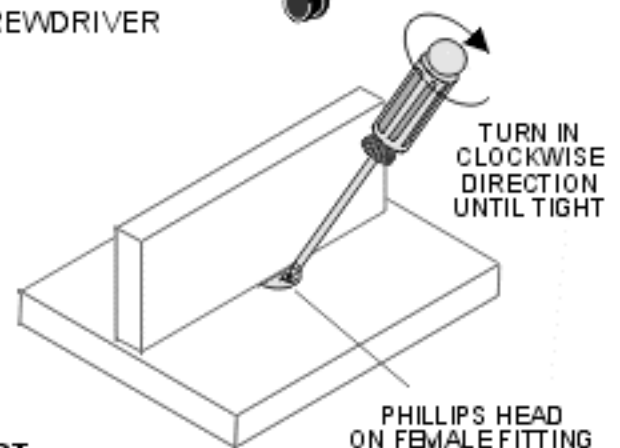
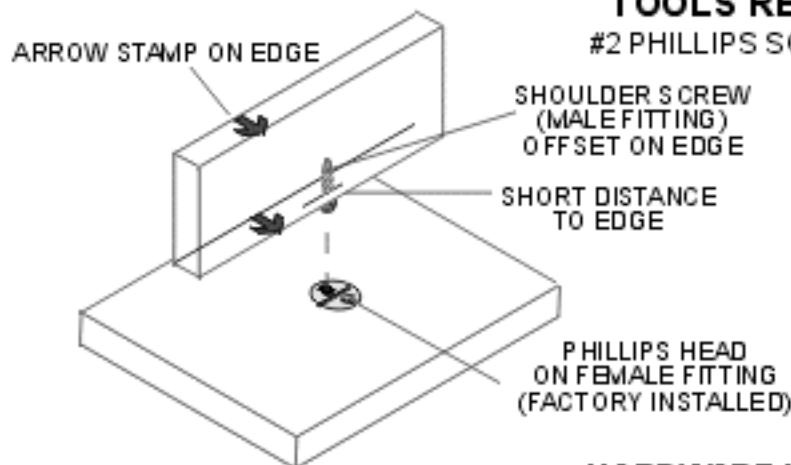

## HARDWARE LIST

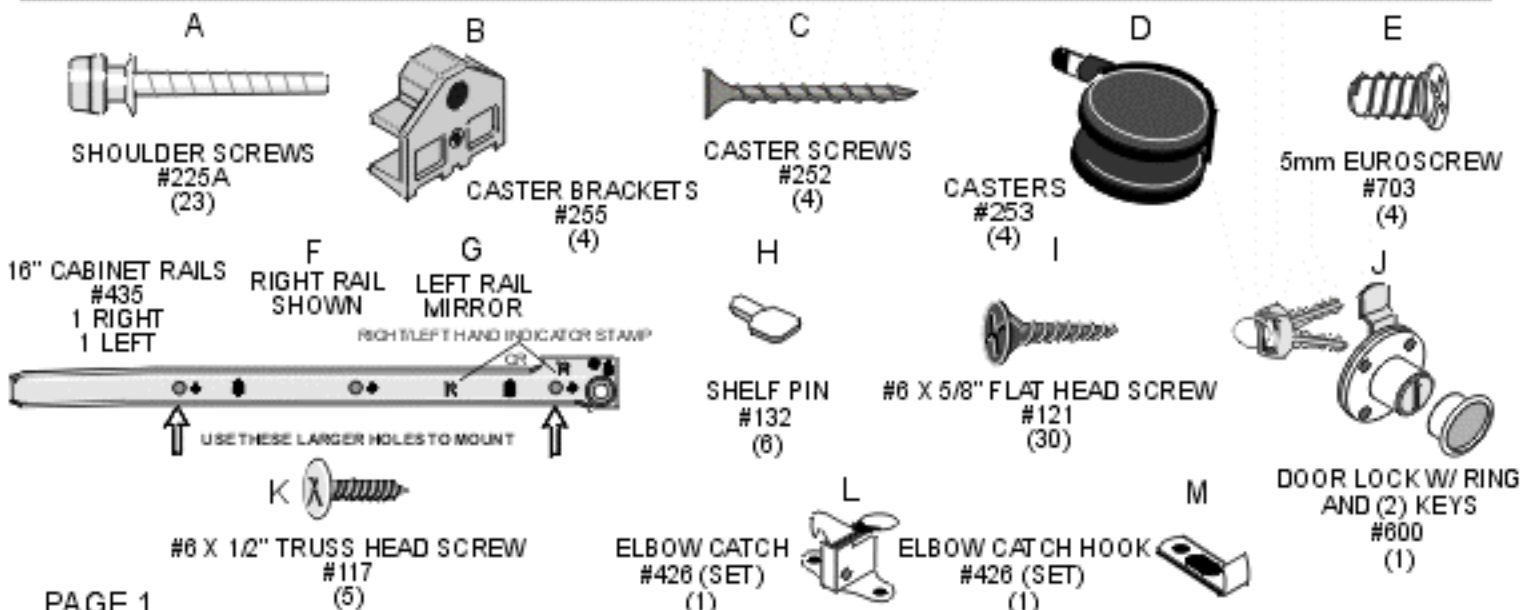

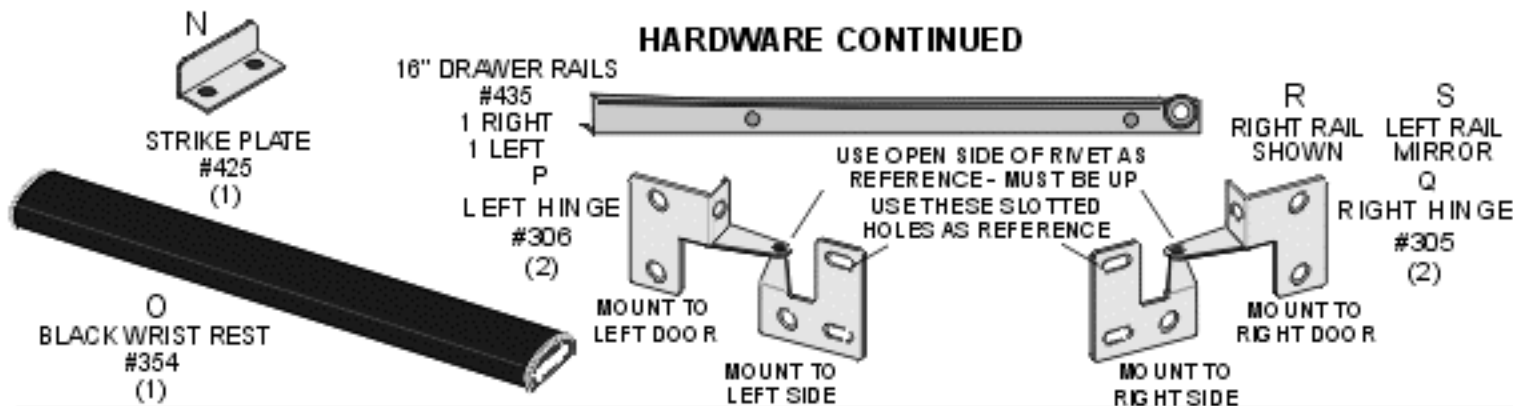

### 1. IDENTIFY ALL PARTS.

If any parts are missing OR you have questions about assembly, please call CUSTOMER SERVICE 1-800-966-5511 Monday - Friday 8am. TO 4:30pm. (Central)

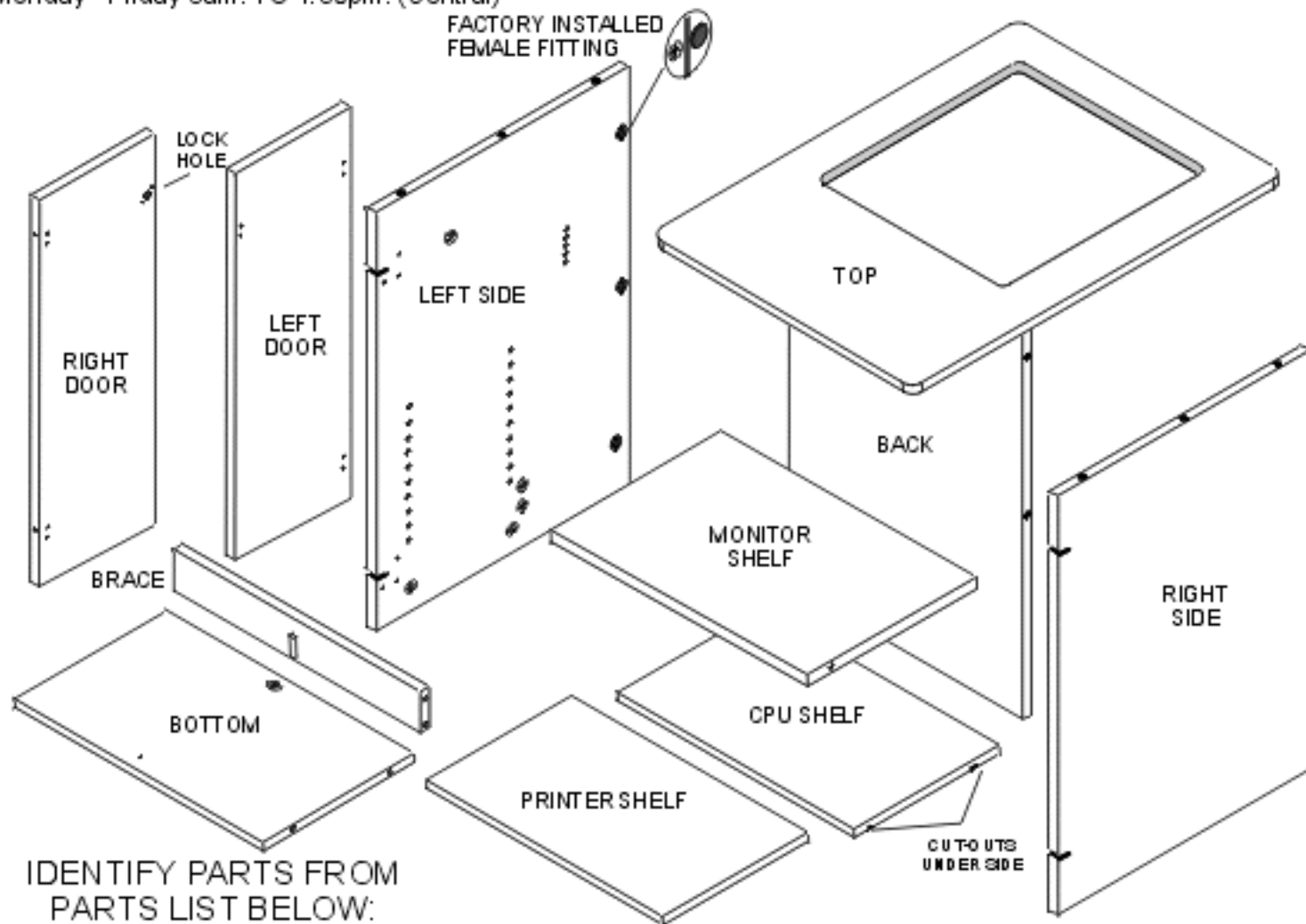

IDENTIFY PARTS FROM PARTS LIST BELOW:

NO.	WOOD PART LIST	WOOD PART SIZES			WOOD PART NUMBERS
		THICKNESS	WIDTH	LENGTH	
1	RIGHT SIDE	5/8"	X.24'	X.34'	110-RSIDE + COLOR
1	LEFT SIDE	5/8"	X.24'	X.34'	110-LSIDE
1	BOTTOM	5/8"	X.14'	X.22'	110-BOTTOM
1	TOP	5/8"	X.24-1/16"	X.32'	110-TOP
1	BRACE	5/8"	X.4'	X.22'	110-BRACE
1	MONITOR SHELF	5/8"	X.14'	X.22'	110-MONSHELF
1	PRINTER SHELF	5/8"	X.15-1/2'	X.21"	110-PRNSHFL
1	CPU SHELF	5/8"	X.14'	X.22'	110-CPUSHELF
1	BACK	5/8"	X.22'	X.34'	110-BACK
2	DOORS	5/8"	X.10-7/8'	X.32-1/8'	110-DOORS

## 2. CASTER BRACKET AND CASTER INSTALLATION

Lay RIGHT and LEFT SIDES on a flat, non-scratch surface, assembly fittings facing up. **ALIGN** CASTER BRACKETS (B) with hole on bottom edge of panel. NOTE: Large hole on CASTER BRACKET must be to inside (fitting side) of panel. Start BRACKET onto board at one corner first. Push BRACKET all the way onto panel. **ATTACH** with CASTER SCREW (C) through mounting hole. **INSERT** CASTER stem into larger mounting hole in BRACKET and push until it "CLICKS" into place. (FIG. 2) - SEE BELOW FOR LARGER VIEW OF SIDE.

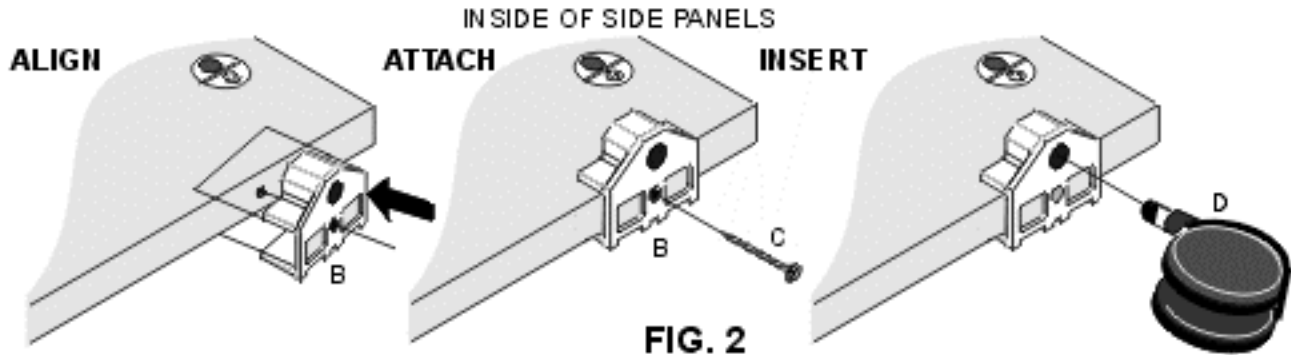

## 3. DETERMINE POSITION OF SHELVES

Decide the best internal shelf arrangement for equipment to be used in the unit. A series of pre-drilled holes on SIDES have been provided to allow for maximum flexibility of CPU and PRINTER SHELF configurations.

Determine mounting position of printer shelf rails based on printer to be used. Measure over-all height of printer, including paper guides and/or tractor feed assembly, if any. For DOT MATRIX printers, BOTTOM of unit may be used for input paper storage. For LASER JET or INK JET printers, shelf rail may be mounted at lowest position in series of holes on SIDES for maximum access. Measure height of CPU to determine position for CPU SHELF on adjustable SHELF PINS. Consider DEPTH of CPU and any possible contact with underside of MONITOR SHELF.

FIG. 3 shows configuration with CPU above PRINTER. This arrangement may be reversed by mounting PRINTER SHELF RAILS at higher position and CPU SHELF below.

**PROCEED TO PAGE 4 -  
HARDWARE INSTALLATION**

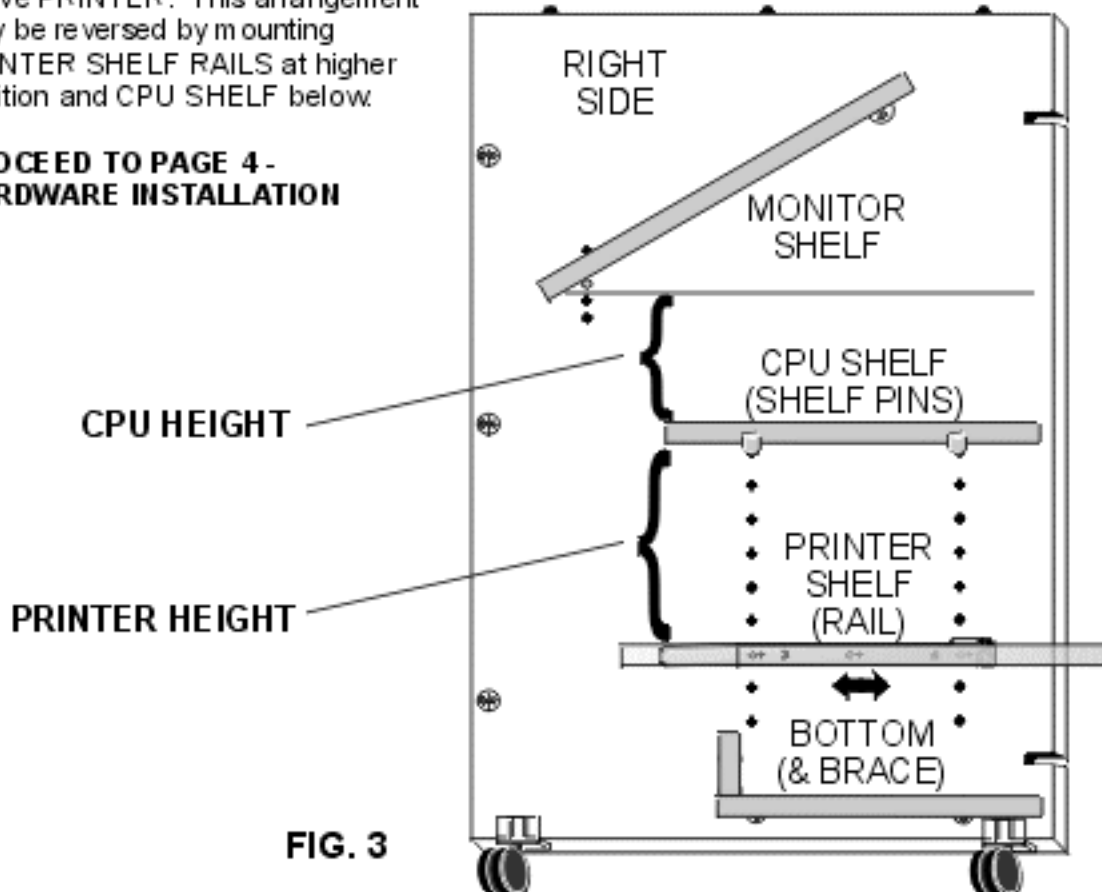

## 4. PREPARE DOORS

Lay RIGHT and LEFT DOORS on a flat, non-scratch surface, hardware mounting holes facing up. FIG. 4

On RIGHT DOOR align and attach (2) RIGHT DOOR HINGES (Q) as indicated using (3) #6 X 5/8" FLAT HEAD SCREWS (I) each. **NOTE:** Open side of HINGE RIVET must face upwards (SEE HARDWARE LIST for direction of hinge references).

Align (1) DOOR LOCK (J) with large mounting hole in RIGHT DOOR as shown. Press-fit DOOR LOCK FINISHING RING over barrel of DOOR LOCK from opposite side. **NOTE:** Insure CAM on lock faces in opposite direction of hinges. Attach with (2) #6 X 5/8" FLAT HEAD SCREWS (I)

On LEFT DOOR align and attach (2) LEFT DOOR HINGES (P) as indicated using (3) #6 X 5/8" FLAT HEAD SCREWS (I) each. **NOTE:** Open side of HINGE RIVET must face upwards (SEE HARDWARE LIST for direction of hinge references). Align (1) STRIKE PLATE with (2) pre-drilled holes near other edge of LEFT DOOR using (2) #6 X 1/2" TRUSS HEAD SCREWS (K). **NOTE:** Projection on STRIKE PLATE mounts even with edge of DOOR as shown. Align and attach (1) ELBOW CATCH (L) to lower portion of door using (2) #6 X 1/2" TRUSS HEAD SCREWS (K). **NOTE:** Projection on ELBOW CATCH faces downward.

**SET DOORS ASIDE FOR LATER ATTACHMENT TO SIDES.**

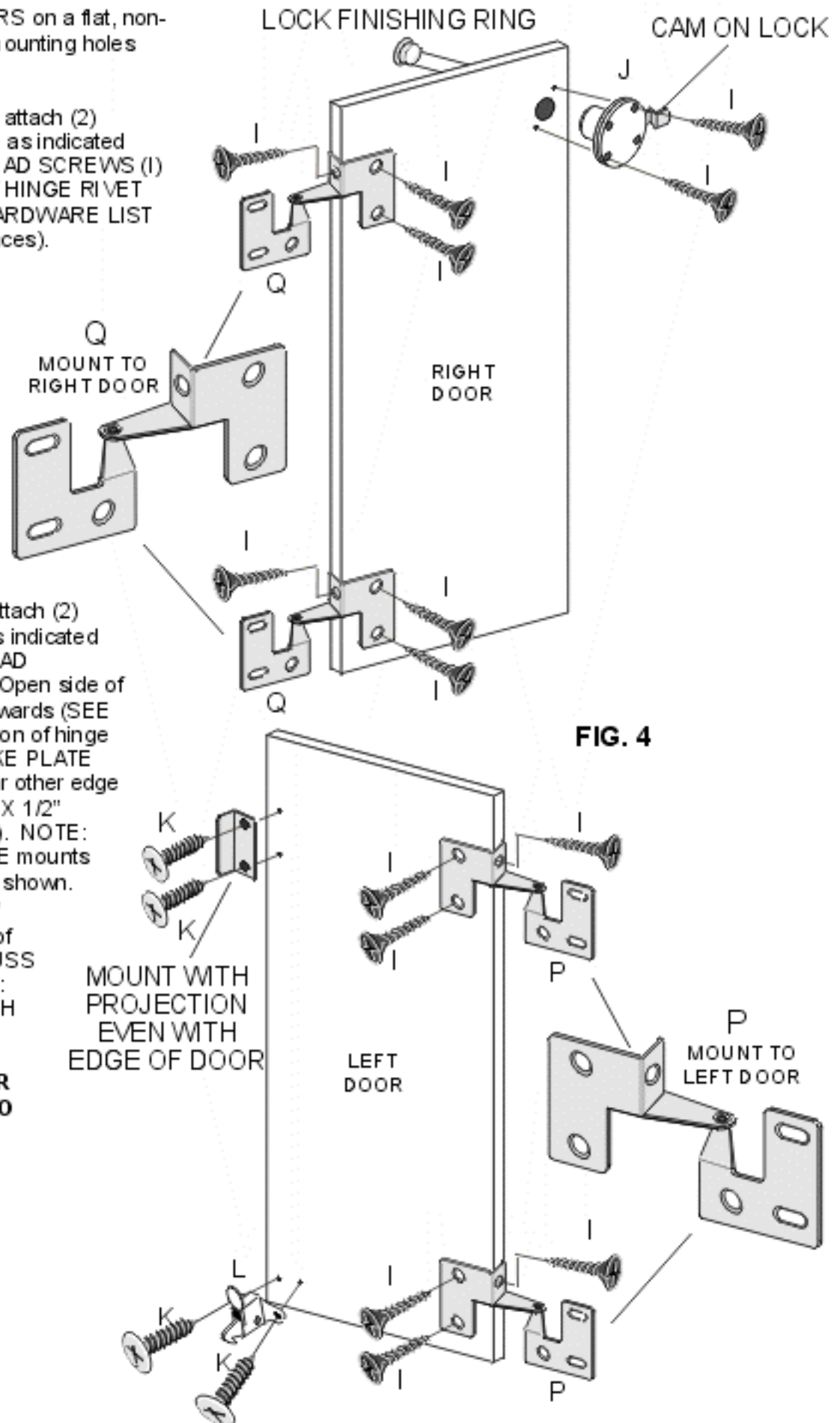

## HARDWARE INSTALLATION TO DESIRED CONFIGURATION

Assembly of CABINET RAILS and shelf pins determined to your desired configuration and may vary slightly from figures as shown.

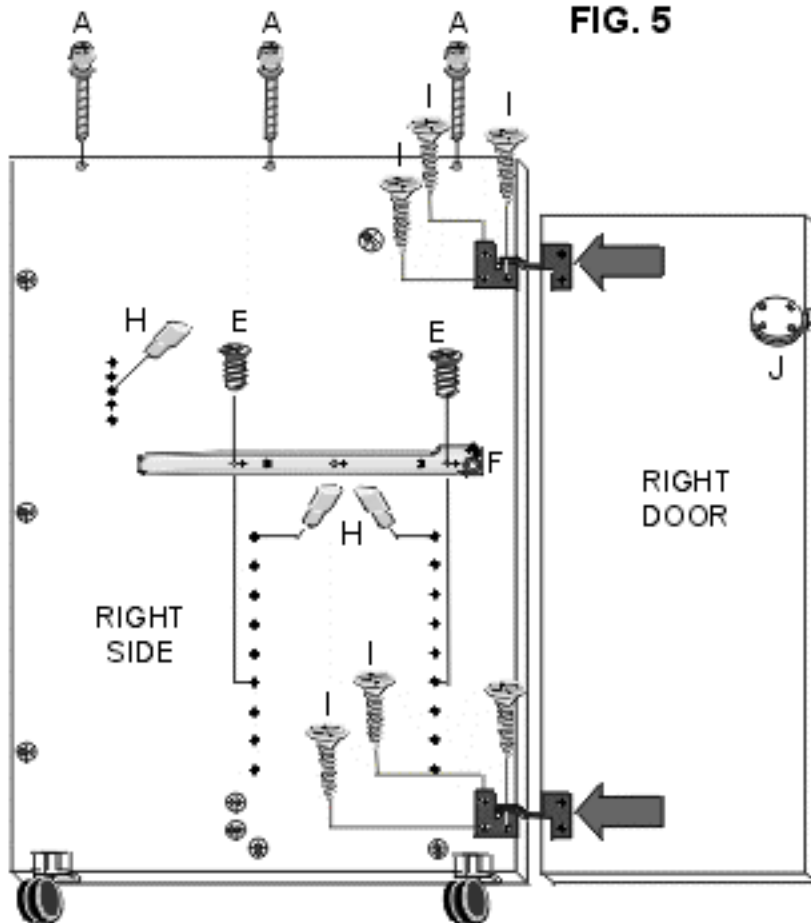

FIG. 5

## DETAIL

RIGHT/LEFT HAND INDICATOR STAMP



## 5. RIGHT SIDE

Insert (1) SHELF PIN (H) into middle hole in series of (5) holes near back-upper portion of panel. FIG. 5 Align and attach (1) 16" RAIL (F) at desired position using (2) 5mm EUROSCREWS (E). Insert (2) SHELF PINS (H) for desired location of CPU SHELF.

Align and attach (1) RIGHT DOOR to RIGHT SIDE using (3) #6 x 5/8" FLAT HEAD SCREWS (I). Insure that LOCK is in position as shown in relation to RIGHT SIDE.

Install (3) SHOULDER SCREWS (A) along top edge of SIDE as shown. Tighten until snug. **DO NOT OVER-TIGHTEN.**

## 6. LEFT SIDE

Insert (1) SHELF PIN (H) into middle hole in series of (5) holes near back-upper portion of panel. FIG. 6 Align and attach (1) 16" LEFT CABINET RAIL (G) at desired position using (2) 5mm EUROSCREWS (E). Insert (2) SHELF PINS (H) for desired location of CPU SHELF at same level as RIGHT SIDE.

Align and attach (1) LEFT DOOR using (3) #6 x 5/8" FLAT HEAD SCREWS (I).

Install (3) SHOULDER SCREWS (A) along top edge of SIDE as shown. Tighten until snug. **DO NOT OVER-TIGHTEN.**

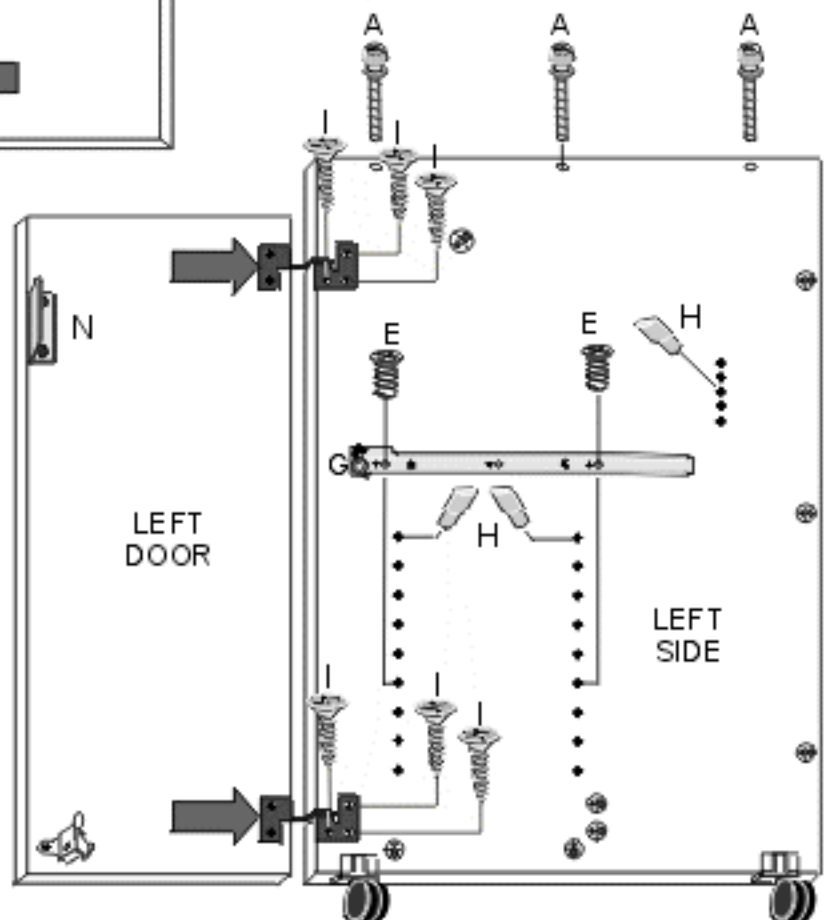
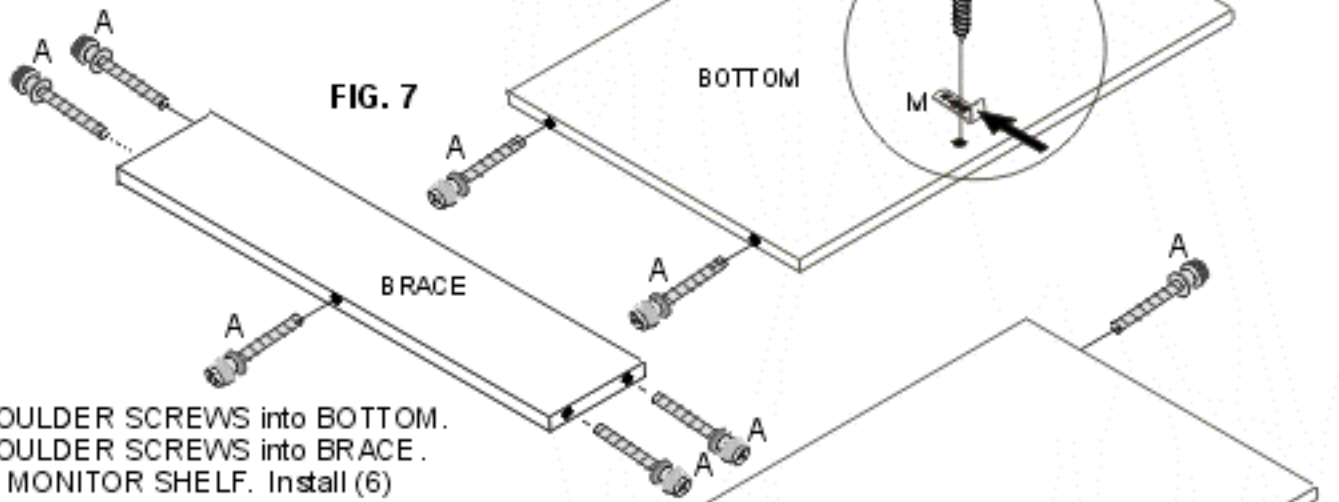

FIG. 6



## 7. INSTALL SHOULDER SCREWS

Install SHOULDER SCREWS (A) into pre-drilled holes in edges of panels as shown. FIG. 7 **DO NOT OVER-TIGHTEN.** Install (1) ELBOW CATCH HOOK (M) to pre-drilled hole on face of BOTTOM using (1) #6 x 1/2" TRUSS HEAD SCREW (K). **BEFORE** tightening screw completely, hold PLATE back into position (perpendicular to edge) and against screw as shown.



Install (4) SHOULDER SCREWS into BOTTOM.  
Install (5) SHOULDER SCREWS into BRACE.  
Install (2) into MONITOR SHELF. Install (6) SHOULDER SCREWS into BACK. FIG. 7

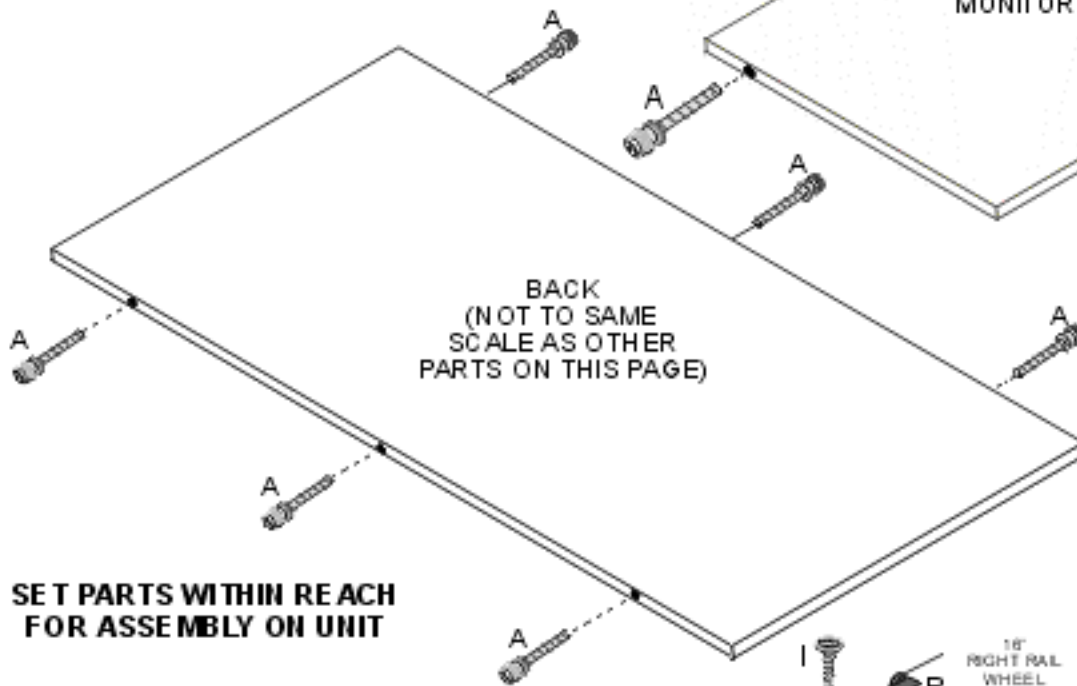

**SET PARTS WITHIN REACH  
FOR ASSEMBLY ON UNIT**

Lay PRINTER SHELF on a flat, non-scratch surface, rail mounting holes facing up. Align and attach (2) 16" DRAWER RAILS as shown using (2) #6 X 5/8" FLAT HEAD SCREWS (I). NOTE: Position of WHEELS on DRAWER RAILS are to the REAR of the PRINTER SHELF. DRAWER RAILS mount even with FRONT edge of SHELF.

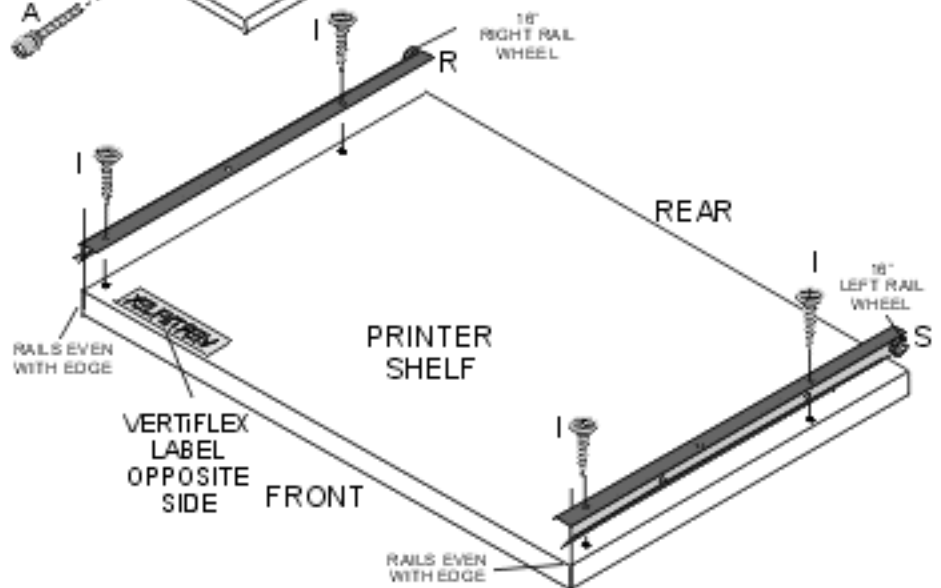

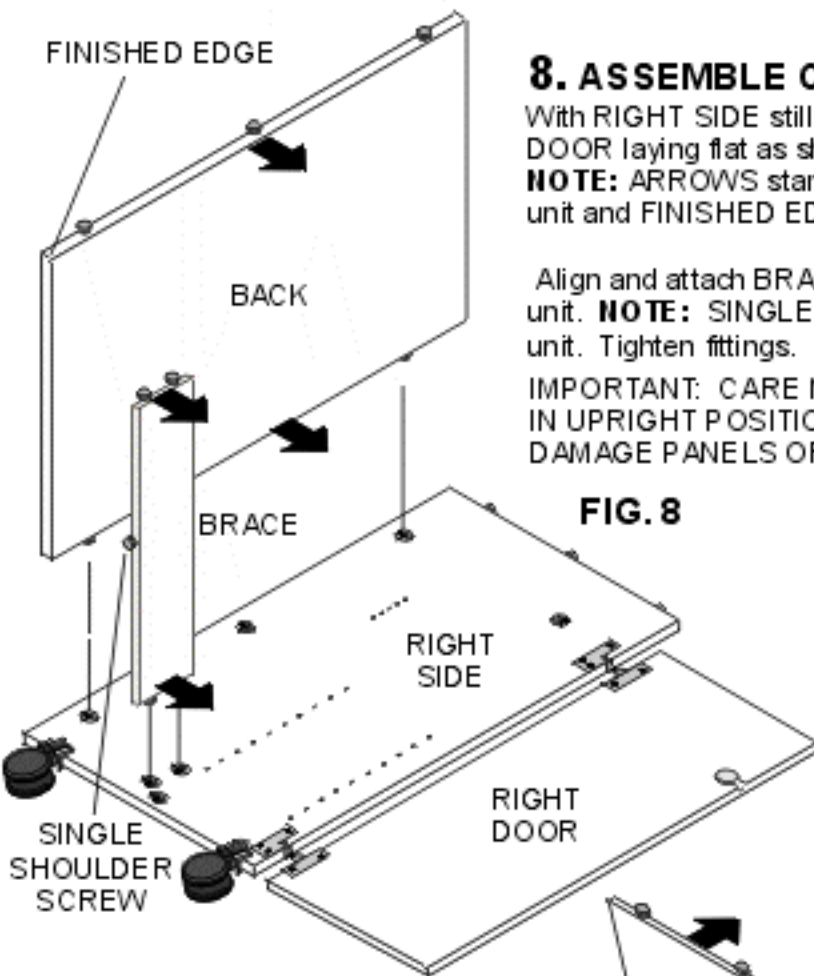

## 8. ASSEMBLE CABINET

With RIGHT SIDE still laying on a flat, non-scratch surface, RIGHT DOOR laying flat as shown, align and attach BACK to RIGHT SIDE. **NOTE:** ARROWS stamped on edge of panel must face toward front of unit and FINISHED EDGE as shown.. FIG. 8 Tighten fittings.

Align and attach BRACE to RIGHT SIDE, ARROWS facing to front of unit. **NOTE:** SINGLE SHOULDER SCREW on edge faces bottom of unit. Tighten fittings.

**IMPORTANT:** CARE MUST BE TAKEN TO KEEP ATTACHED PANELS IN UPRIGHT POSITION UNTIL FULLY ASSEMBLED SO AS TO NOT DAMAGE PANELS OR FITTINGS.

FIG. 8

## 9. ASSEMBLE CABINET

Align and attach BOTTOM to RIGHT SIDE and then to BRACE. **NOTE:** ARROWS stamped on edge of panel must face toward top of unit. FIG. 9 Tighten fittings.

Align and attach MONITOR SHELF, ARROWS on edge facing as shown, to RIGHT SIDE.. Tighten fittings.

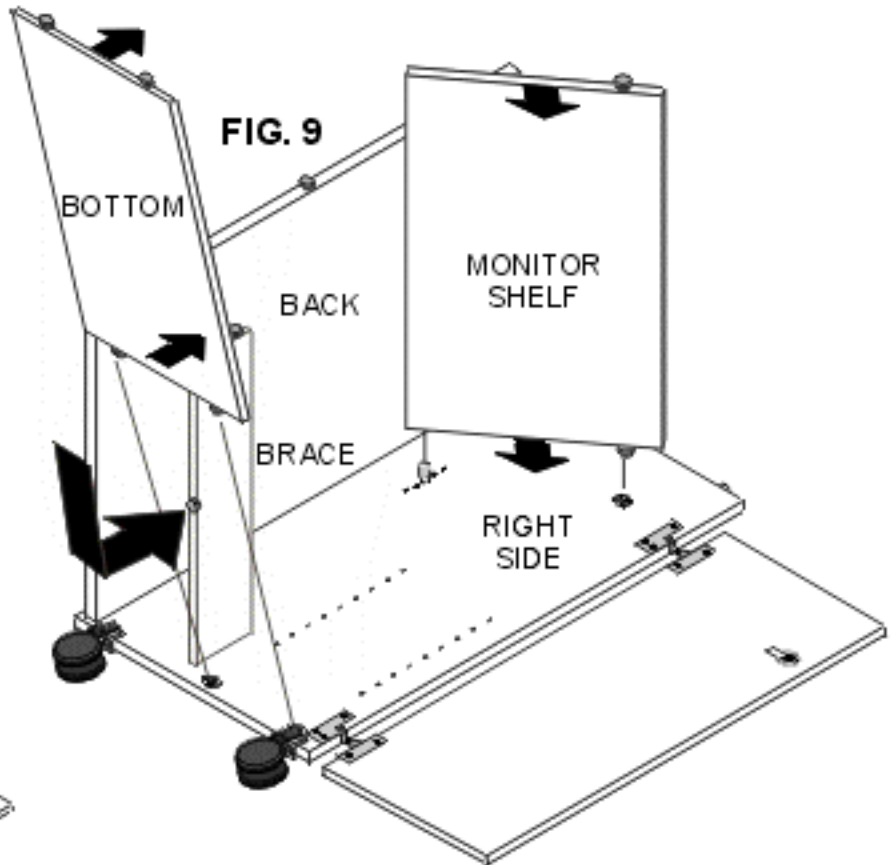

FIG. 9

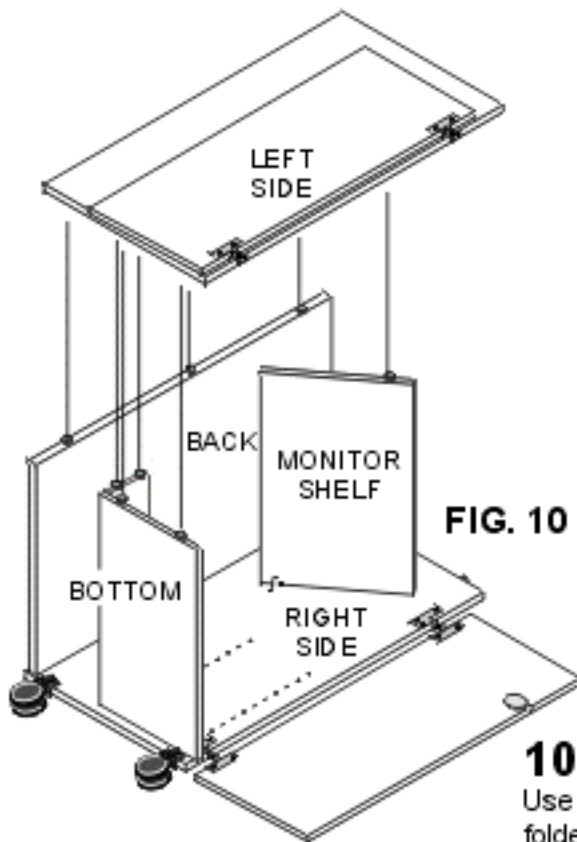

FIG. 10

## 10. ASSEMBLE CABINET

Use 2 people to CAREFULLY lift LEFT SIDE with LEFT DOOR folded in open position as shown. Align and attach LEFT SIDE to MONITOR SHELF, BOTTOM, BRACE and BACK. FIG. 10 From under LEFT SIDE tighten all fittings.

## 11. CLOSE AND LOCK DOORS

Close and lock doors as shown. FIG. 11 Using 2 people, carefully stand unit up onto casters.

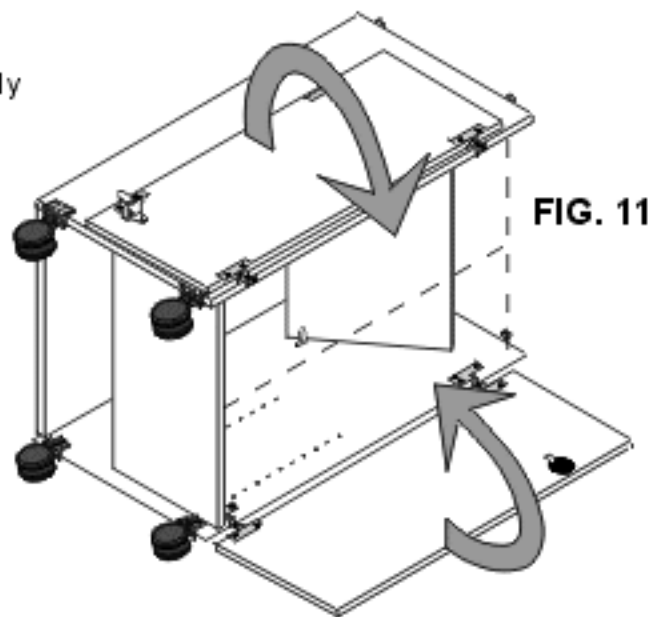
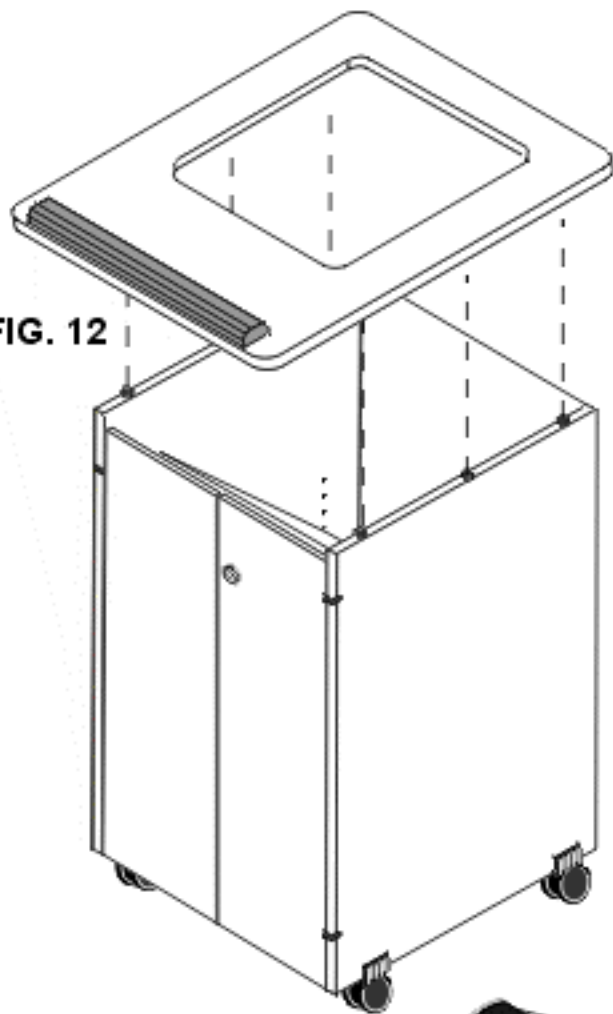

FIG. 12



## 12. INSTALL TOP

Align and attach TOP to RIGHT and LEFT SIDES. FIG. 12 Open DOORS and tighten all fittings from under TOP.

FIG. 13

O  
BLACK WRIST REST

REMOVE PAPER LINER

## 13. WRIST REST AND SHELVES

Install CPU SHELF onto SHELF PINS. Install PRINTER SHELF onto RAILS. Align wheel on PRINTER SHELF RAIL above and behind wheel on CABINET RAILS. Push shelf in to engage RAILS.

NOTE: CARE MUST BE TAKEN IN POSITIONING WRIST REST ONTO KEYBOARD AREA. ONCE ADHESIVE IS ACTIVATED, WRIST REST MAY NOT BE REPOSITIONED.

Remove paper liner from adhesive strip on the back of WRIST REST (O). FIG. 13 Carefully align WRIST REST along front edge of KEYBOARD area of TOP - centering it from side to side. Press WRIST REST onto shelf to secure.

